

# Neles™ SwitchGuard™

## SG9000H Rev. 1.2

Installation, maintenance and  
operating instructions

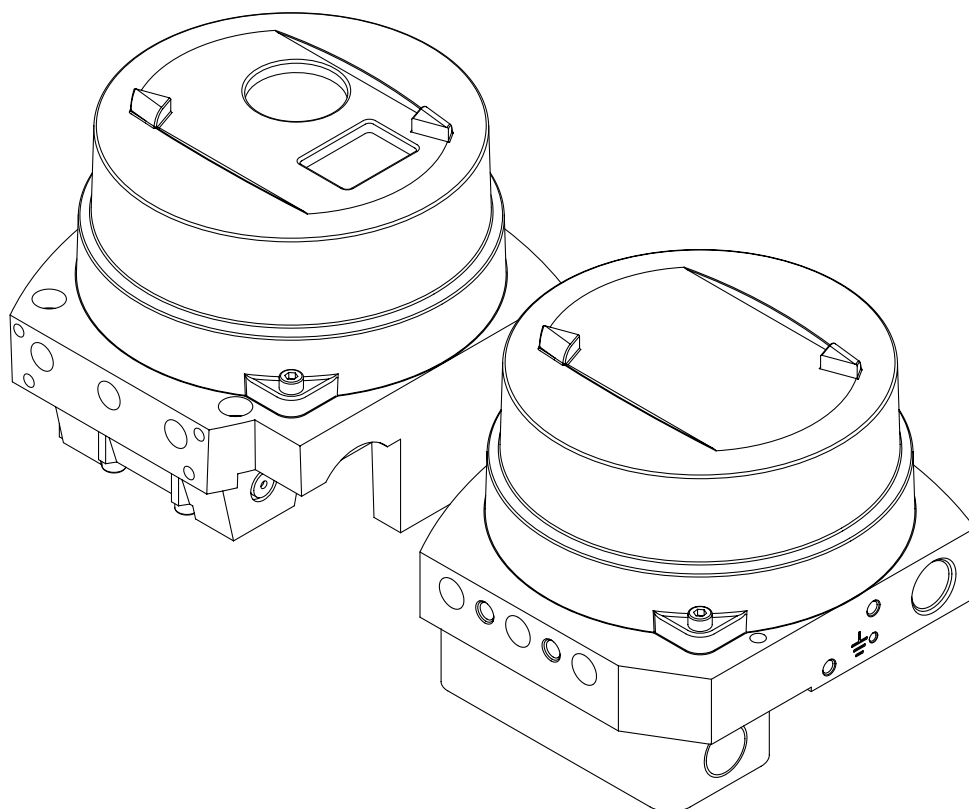

# Table of contents

<b>SG9000H SWITCHGUARD INTELLIGENT ON/OFF CONTROLLER WITH HART COMMUNICATION</b>	<b>3</b>	<b>TROUBLE SHOOTING</b>	<b>21</b>
General	3	<b>SG9_H/R_, SG9_H/I_, SG9_H/K_ (WITH LIMIT SWITCHES)</b>	<b>21</b>
Technical description	3	Introduction	21
Markings	3	SG9_/R_, SG9_/I_ or SG9_/K_ on a valve controller	23
Technical specifications	4	Electrical connections	23
Recycling and disposal	6	Adjustment	23
Safety precautions	6	Removal of the limit switches SG9_/R_, SG9_/I_ or SG9_/K_ for accessing the valve controller	24
<b>TRANSPORTATION, RECEPTION AND STORAGE</b>	<b>7</b>	Circuit diagrams	24
<b>MOUNTING</b>	<b>7</b>	Maintenance	24
General	7	<b>TOOLS</b>	<b>24</b>
Mounting on Neles actuators with VDI/VDE mounting face	7	<b>ORDERING SPARE PARTS</b>	<b>24</b>
Mounting on linear actuator with IEC 60534 mounting face	7	<b>DRAWINGS AND PARTS LISTS</b>	<b>25</b>
Mounting and installation of SG9300	8	Exploded view and parts list, SG9000H	25
Piping	9	Exploded view and parts list, SG9_/R_, SG9_/I_, SG9_/K_	27
Electrical connections	12	Mounting parts for Neles actuators with VDI/VDE mounting face	29
<b>LOCAL USER INTERFACE (LUI)</b>	<b>13</b>	Mounting parts for Quadra-Powr® actuators	29
Measurement monitoring	13	Mounting parts for linear actuators	30
Guided start-up	13	Connection diagrams	31
Configuration menu	14	<b>CONTROL DRAWINGS</b>	<b>35</b>
MODE menu	14	<b>DIMENSIONS</b>	<b>36</b>
Configuration parameters	15	<b>CONFIGURATION PARAMETERS</b>	<b>41</b>
Valve travel calibration	17	<b>EU DECLARATION OF CONFORMITY</b>	<b>42</b>
Special displays	17	<b>TYPE CODING</b>	<b>43</b>
HART write protection	18		
<b>MAINTENANCE</b>	<b>18</b>		
Opening and closing of the cover	18		
Prestage	18		
Spool valve	19		
Communication circuit board	19		
<b>ERROR MESSAGES</b>	<b>20</b>		
Failsafe errors	20		
Alarms	20		
Errors	20		
Warnings	20		
Notifications	21		

## READ THESE INSTRUCTIONS FIRST!

These instructions provide information about safe handling and operation of the valve.

If you require additional assistance, please contact the manufacturer or manufacturer's representative.

Addresses and phone numbers are printed on the back cover.

## SAVE THESE INSTRUCTIONS!

Subject to change without prior notice

Neles, Jamesbury and Easyflow by Neles, and certain other trademarks, are either registered trademarks or trademarks of Neles Corporation or its subsidiaries or affiliates in the United States and/or in other countries.

# 1. SG9000H SWITCHGUARD INTELLIGENT ON/OFF CONTROLLER WITH HART COMMUNICATION

## 1.1 General

This manual incorporates Installation, Maintenance and Operation Instructions for the Neles SwitchGuard. The SG9000H may be used with either cylinder or diaphragm type pneumatic actuators for rotary or linear valves.

**NOTE:**

The selection and use of the valve controller in a specific application requires close consideration of detailed aspects. Due to the nature of the product, this manual cannot cover all the likely situations that may occur when installing, using or servicing the valve controller. If you are uncertain about the use of the controller or its suitability for your intended use, please contact Valmet for more information.

## 1.2 Technical description

The SwitchGuard is a 4–20 mA loop-powered microcontroller-based on/off controller. Binary 24 V DC signal can be used via optional U/I converter. The SwitchGuard operates even at 3.6 mA input signal (see restrictions in Section 4.5.3) and communicates via HART. The device contains a Local User Interface enabling local configuration. A PC with FieldCare software can be connected to the SwitchGuard itself or to the control loop.

The powerful 32-bit microcontroller controls the valve position. The measurements include:

- Input signal
- Valve position with contactless sensor
- Actuator pressures, 2 independent measurements
- Supply pressure
- Device temperature

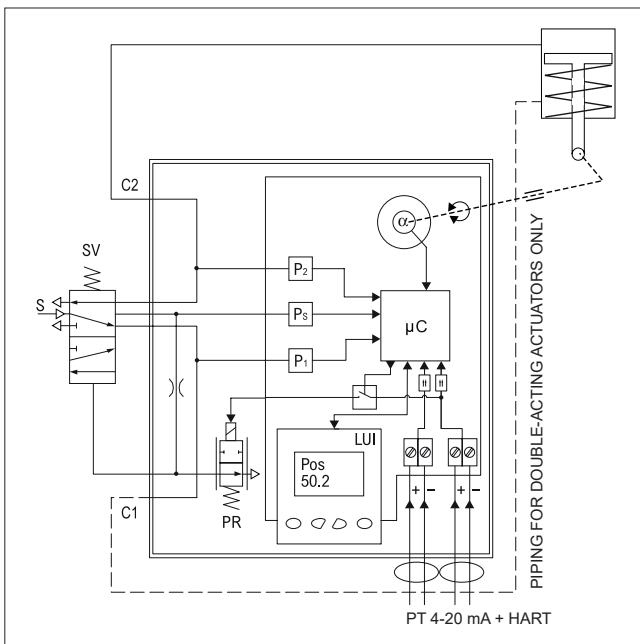

Fig. 1 The principle of operation

Advanced self-diagnostics guarantees that all measurements operate correctly. Failure of one measurement does not cause the valve to fail if the input signal and position measurements are operating correctly. After connections of electric signal and pneumatic supply the micro controller ( $\mu\text{C}$ ) reads the input signal, position sensor (a) and pressure sensors (Ps, P1, P2). A difference between setpoint according to stroke curve and position sensor (a) measurement is detected by the control algorithm inside the  $\mu\text{C}$ . The  $\mu\text{C}$  calculates a new value for prestage (PR) coil current based on this information. Changed current to the PR changes the pilot pressure to the spool valve. Reduced pilot pressure moves the spool and the actuator pressures change accordingly. The spool opens the flow to the driving side of the double-acting actuator (or air side in the single acting-actuator) and opens the flow out from the other side of the actuator in case of double-acting. The increasing pressure will move the piston. The actuator and feedback shaft rotate clockwise.

## 1.3 Markings

The valve controller is equipped with an identification plate (Fig. 2).

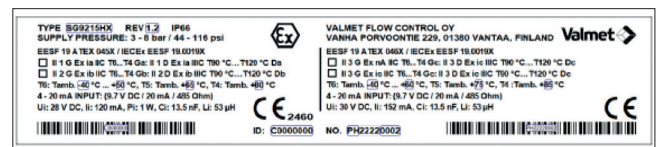

Fig. 2 Examples of identification plate

Identification plate markings include:

- Type designation of the on/off controller
- Revision number
- Enclosure class
- Certificate number
- Hazardous area approval
- Temperatures classes
- Input signal and electrical values
- Supply pressure range
- Manufacturer
- CE mark
- ID code
- Manufacturing serial number TTYWWNNNN\*)

\*) Manufacturing serial number explained:

- TT= device and factory sign
- YY= year of manufacturing
- WW = week of manufacturing
- NNNN = consecutive number

Example: PH13011234 = controller, year 2013, week 1, consecutivenumber 1234.

**NOTE:**

When installing the device, mark the applied hazardous area installation method by ticking the applicable box in the product identification plate when applicable.

## 1.4 Technical specifications

**Ex NOTE:**

This manual contains technical specifications for several types of the SG9000H valve controller. If in doubt, refer to the type approval certificate of the respective version. The certificate is delivered with the field device and is also available from the manufacturer.

## SG9000H INTELLIGENT ON/OFF CONTROLLER

### General

Loop powered, no external power supply required.

Suitable for rotary and sliding-stem valves.

Actuator connections in accordance with VDI/VDE 3845 and IEC 60534-6 standards.

Action:	Double or single acting
Travel range:	Linear: 10–120 mm Rotary: 45–95° Measurement range 110° with freely rotating feedback shaft

### Environmental influence

Standard temperature range: -40° to +85 °C / -40° to +185 °F

Low temperature option: -40° to +60 °C / -40° to +140 °F

Influence of temperature on valve position: < 0,5 % / 10 °C

Influence of vibration on valve position:  
under 2g 5–150 Hz,  
1g 150–300 Hz, 0.5g 300–2000 Hz  
Open and closed position: no effect  
Deviation from profile: <10 %

### Enclosure

Material (SG92\_): Epoxy coated anodised aluminium alloy, glass window (excluding E2)

Material (VG93\_): Stainless steel (316 or equivalent), glass window as an option

Mechanical position indicator and LUI visible through the main cover (SG92\_).

Protection class: IP66, NEMA 4X

Pneumatic ports:  
SG9\_1\_ 1/4 NPT  
SG9235 1/2 NPT  
SG9237 1 NPT (1/2 NPT supply)  
(single acting only)

Conduit entry thread: M20 x 1.5

Weight:  
SG921\_ 3.0 kg / 6.6 lb  
SG9235 4.6 kg / 10.1 lb  
SG9237 5.0 kg / 11 lb  
SG931\_ 9.0 kg / 19.8 lb

SG92\_ with extension housing plus 1.0 kg / 2.2 lb

SG93\_ with extension housing plus 3.0 kg / 6.6 lb

### Pneumatics

Spool material: Hard anodised aluminium with special teflon coating

Supply pressure: 3–8 bar / 44–116 psi

Output pressure: 3–8 bar / 44–116 psi

Air quality: According to ISO 8573-1:2001  
Solid particles: Class 6

Humidity: Class 1  
(dew point 10 °C / 18 °F below minimum temperature is recommended)

Oil class: 3 (or < 1 ppm)

Supply media: Air, nitrogen

Capacity with 4 bar / 60 psi supply:

SG9_12	7 Nm <sup>3</sup> /h / 4.1 scfm (Cv = 0.06)
SG9_15	90 Nm <sup>3</sup> /h / 53 scfm (Cv = 0.7)
SG9235	380 Nm <sup>3</sup> /h / 223 scfm (Cv = 3.2)
SG9237	feed 380 Nm <sup>3</sup> /h / 223 scfm (Cv = 3.2) exhaust 700 Nm <sup>3</sup> /h / 412 scfm (Cv = 6.4)

Consumption with 4 bar / 60 psi supply:

actuator pressurized 0.22 Nm<sup>3</sup>/h / 0.13 scfm,  
actuator vented 0.25 Nm<sup>3</sup>/h / 0.15 scfm

### Electronics

Electrical connections (incl. junction box): max. 0.25–2.5 mm<sup>2</sup> (solid or flexible conductors)

Torque value for the tightening of screws (incl. junction box): 0.6–0.8 Nm

### HART

Connections:	'+' and '-'
Supply power:	Loop powered, 4–20 mA
Minimum signal:	3.6 mA (see restrictions in 4.5.3)
Current max :	23 mA
Load voltage:	up to 9.7 V DC/20 mA (corresponding 485 Ω)
Voltage:	max. 30 V DC
Polarity protection:	-30 V DC
Over current protection:	active over 36 mA
Max power dissipation:	1.05 W with position transmitter 1.74 W

### Position transmitter (optional)

Connections:	PT: '+' and '-'
Output signal:	4–20 mA (galvanic isolation; 600 V DC) (fault modes indicated by levels 3.5 and 22 mA)
Supply voltage:	12–30 V
Resolution:	16 bit / 0.244 μA
Linearity:	< 0.05 % FS
Temperature effect:	< 0.35 % FS
External load:	max 0–780 Ω max 0–690 Ω for intrinsically safe Local user interface functions

- Monitoring of valve position, input signal, temperature, supply and actuator pressure difference
- Guided start-up function
- LUI may be locked remotely to prevent unauthorised access
- Calibration: Automatic
- Tuning
- Mode selection: Automatic/Manual
- Position trigger level
- Stroke times, stroke profiles
- Dead angle
- Maximum speed
- Positioner fail action, open/close
- Signal direction: Direct/reverse acting
- Actuator type: double/single acting
- Valve type: rotary/linear IEC
- Language selection: English, German and French

### Remote user interface functions

Configuration and diagnostic information is presented in easily understandable way using FDT/DTM technology, such as fdtCONTAINER.

## APPROVALS

Table 1 Approvals and electrical values

Certificate	Approval	Electrical values
<b>ATEX</b>		
<b>SG9_X (ATEX)</b> EESF 19 ATEX 045X  EN 60079-0: 2018, EN 60079-11: 2012, EN 60079-31: 2014	II 1 G Ex ia IIC T6...T4 Ga I 1 D Ex ia IIIC T90 °C...T120 °C Da II 1 D Ex ta IIIC T90 °C...T120 °C Da II 2 G Ex ib IIC T6...T4 Gb II 2 D Ex ib IIIC T90 °C...T120 °C Db II 2 D Ex tb IIIC T90 °C...T120 °C Db	Input: $U_i \leq 28 \text{ V}$ , $I_i \leq 120 \text{ mA}$ , $P_i \leq 1.0 \text{ W}$ , $C_i \leq 13.5 \text{ nF}$ , $L_i \leq 53 \mu\text{H}$ PT: $U_i \leq 28 \text{ V}$ , $I_i \leq 120 \text{ mA}$ , $P_i \leq 1.0 \text{ W}$ , $L_i \leq 53 \mu\text{H}$ , $C_i \leq 13.5 \text{ nF}$
<b>SG9_X (ATEX)</b> EESF 19 ATEX 046X  EN IEC 60079-0: 2018, EN 60079-11: 2012, EN 60079-31: 2014, EN 60079-15: 2010	II 3 G Ex nA IIC T6...T4 Gc II 3 D Ex ic IIIC T90 °C...T120 °C Dc II 3 D Ex tc IIIC T90 °C...T120 °C Dc  II 3 G Ex ic IIC T6...T4 Gcl I 3 D Ex ic IIIC T90 °C...T120 °C Dcl I 3 D Ex tc IIIC T90 °C...T120 °C Dc	Input: $U_i \leq 30 \text{ V}$ , $I_i \leq 152 \text{ mA}$ PT: $U_i \leq 30 \text{ V}$ , $I_i \leq 152 \text{ mA}$  Input: $U_i \leq 30 \text{ V}$ , $I_i \leq 152 \text{ mA}$ , $C_i \leq 13.5 \text{ nF}$ , $L_i \leq 53 \mu\text{H}$ PT: $U_i \leq 30 \text{ V}$ , $I_i \leq 152 \text{ mA}$ , $C_i \leq 13.5 \text{ nF}$ , $L_i \leq 53 \mu\text{H}$
<b>SG_E6</b> SIRA 11ATEX1006X  EN 60079-0:2012, EN 60079-1:2007, EN 60079-31:2009	II 2 G Ex d IIC T6...T4 Gb II 2 D Ex tb IIIC T80 °C...T105 °C Db IP66	II 2 G Ex d IIC T6...T4 Gb II 2 D Ex tb IIIC T80 °C...T105 °C Db IP66 Input: $U_i \leq 30 \text{ V}$ , $P_i \leq 1.0 \text{ W}$ PT: $U_i \leq 30 \text{ V}$ , $I_i \leq 20 \text{ mA}$ , $P_i \leq 1.0 \text{ W}$
<b>IECEx</b>		
<b>SG_X</b> IECEx EESF 19.0019X  IEC 60079-0:2017, IEC 60079-11:2011, IEC 60079-15:2010, IEC 60079-31:2013	Ex ia IIC T6...T4 Ga Ex ia IIIC T90 °C...T120 °C Da / Ex ta IIIC T90 °C...T120 °C Da Ex ib IIC T6...T4 Gb Ex ib IIIC T90 °C...T120 °C Db / Ex tb IIIC T90 °C...T120 °C Db  Ex nA IIC T6...T4 Gc Ex ic IIIC T90 °C...T120 °C Dc / Ex tc IIIC T90 °C...T120 °C Dc  Ex ic IIC T6...T4 Gc Ex ic IIIC T90 °C...T120 °C Dc / Ex tc IIIC T90 °C...T120 °C Dc	Input: $U_i \leq 28 \text{ V}$ , $I_i \leq 120 \text{ mA}$ , $P_i \leq 1.0 \text{ W}$ , $C_i \leq 13.5 \text{ nF}$ , $L_i \leq 53 \mu\text{H}$ PT: $U_i \leq 28 \text{ V}$ , $I_i \leq 120 \text{ mA}$ , $P_i \leq 1.0 \text{ W}$ , $L_i \leq 53 \mu\text{H}$ , $C_i \leq 13.5 \text{ nF}$  Input: $U_i \leq 30 \text{ V}$ , $I_i \leq 152 \text{ mA}$ PT: $U_i \leq 30 \text{ V}$ , $I_i \leq 152 \text{ mA}$  Input: $U_i \leq 30 \text{ V}$ , $I_i \leq 152 \text{ mA}$ , $C_i \leq 13.5 \text{ nF}$ , $L_i \leq 53 \mu\text{H}$ PT: $U_i \leq 30 \text{ V}$ , $I_i \leq 152 \text{ mA}$ , $C_i \leq 13.5 \text{ nF}$ , $L_i \leq 53 \mu\text{H}$
<b>SG_E6</b> IECEx SIR 11.0001X  IEC 60079-0:2011, IEC 60079-1:2007-04, IEC 60079-31:2008	Ex d IIC T6...T4 Gb Ex tb IIIC T80 °C...T105 °C Db IP66	Input: $U_i \leq 30 \text{ V}$ , $P_i \leq 1.0 \text{ W}$ PT: $U_i \leq 30 \text{ V}$ , $I_i \leq 20 \text{ mA}$ , $P_i \leq 1.0 \text{ W}$
<b>INMETRO</b>		
<b>SG_Z</b> NCC 12.0793 X  ABNT NBR IEC 60079-0:2013 ABNT NBR IEC 60079-11:2009 ABNT NBR IEC 60079-26:2008 versão corrigida 2009 ABNT NBR IEC 60079-27:2010	Ex ia IIC T6...T4 Ga Ex ia IIC T6...T4 Gb	Input: $U_i \leq 28 \text{ V}$ , $I_i \leq 120 \text{ mA}$ , $P_i \leq 1.0 \text{ W}$ , $C_i \leq 22 \text{ nF}$ , $L_i \leq 53 \mu\text{H}$ PT: $U_i \leq 28 \text{ V}$ , $I_i \leq 120 \text{ mA}$ , $P_i \leq 1.0 \text{ W}$ , $L_i \leq 53 \mu\text{H}$ , $C_i \leq 22 \text{ nF}$
<b>SG_Z</b> NCC 12.0794 X  ABNT NBR IEC 60079-0:2013 ABNT NBR IEC 60079-11:2009 IEC 60079-15:2010 ABNT NBR IEC 60079-15:2012 ABNT NBR IEC 60529:2005	Ex nA IIC T6...T4 Gc  Ex ic IIC T6...T4 Gc	Input: $U_i \leq 30 \text{ V}$ , $I_i \leq 152 \text{ mA}$ PT: $U_i \leq 30 \text{ V}$ , $I_i \leq 152 \text{ mA}$  Input: $U_i \leq 30 \text{ V}$ , $I_i \leq 152 \text{ mA}$ , $C_i \leq 22 \text{ nF}$ , $L_i \leq 53 \mu\text{H}$ PT: $U_i \leq 30 \text{ V}$ , $I_i \leq 152 \text{ mA}$ , $C_i \leq 22 \text{ nF}$ , $L_i \leq 53 \mu\text{H}$
<b>SG_E5</b> NCC 12.0796 X  ABNT NBR IEC 60079-0:2013 versão corrigida 2011 ABNT NBR IEC 60079-1:2009 versão corrigida 2011 ABNT NBR IEC 60079-31:2011 ABNT NBR IEC 60529:2005	Ex d IIC T6...T4 Gb Ex tb IIIC T80 °C...T105 °C Db	Input: $U_i \leq 30 \text{ V}$ , $P_i \leq 1.0 \text{ W}$ PT: $U_i \leq 30 \text{ V}$ , $I_i \leq 20 \text{ mA}$ , $P_i \leq 1.0 \text{ W}$
<b>cCSAus</b>		
<b>SG_E2</b> CSA 1980091  CSA Std C22.2 No.25-1966, CSA Std C22.2 No.30-M1986, CAN/CSA-C22.2 No.94-M91, C22.2 No. 142-M1987, CAN/ CSA C22.2 61010-1-04, CAN/CSA-C22.2 No 60079-0-07, CAN/CSA-C22.2 No 60079-1-07, CAN/ CSA C22.2 No 60079-31-12, CAN/CSA-C22.2 No. 60529-05, FM 3600 (1998), FM 3615 (2006), FM 3810 (2005), ANSI/ NEMA 250-1991, ISA 60079-0-07, ISA 60079-1-07, ISA 60079-31- 2009, ANSI/IEC 60529:2004	Class I, Div 1, Groups B, C, D Class II, Div 1, Groups E, F, G Class III: T4...T6, Enclosure type 4X Ex d IIC T6...T4 AEx d IIC T6...T4 Ex tb IIIC T100 °C IP66 AEx tb IIIC T100 °C IP66	Input: $U_i \leq 30 \text{ V}$ , $P_i \leq 1.05 \text{ W}$ PT: $U_i \leq 30 \text{ V}$ , $P_i \leq 1.05 \text{ W}$
<b>SG_U (U1, U2)</b>  CSA C22.2 No. 0-M91, CSA C22.2 No. 94-M91, CSA C22.2 No. 142-M1987, CSA C22.2 No. 157-92, CSA C22.2 No. 213-M1987, CSA C22.2 No. 60079-0:11, CSA C22.2 No. 60079-11:11, CSA C22.2 No. 60079-15:12, CSA C22.2 No. 60529:05, ANSI/ISA 60079-0: 2009, ANSI/ISA 60079-11: 2012, ANSI/ISA 60079-15: 2012, FM 3600 November 1998, FM 3610 October 1999, FM 3611 October 1999, FM 3810- 2005, ANSI/NEMA 250:1991, ANSI/IEC 60529:2004	IS Class I, Div 1, Groups A, B, C, D, T6...T4 IS Class I, Zone 0, AEx ia, IIC T6...T4  NI Class I, Div 2, Groups A, B, C, D, T6...T4 NI Class I, Zone 2, Ex nA IIC, T6...T4	IS Input: $U_i (V_{\text{max}}) = 28 \text{ V}$ , $I_i (I_{\text{max}}) = 120 \text{ mA}$ , $P_i = 1 \text{ W}$ , $C_i = 22 \text{ nF}$ , $L_i = 53 \mu\text{H}$ Output: $U_i (V_{\text{max}}) = 28 \text{ V}$ , $I_i (I_{\text{max}}) = 120 \text{ mA}$ , $P_i = 1 \text{ W}$ , $C_i = 22 \text{ nF}$ , $L_i = 53 \mu\text{H}$

## Electromagnetic protection

Emission acc. to EN 61000-6-4

Immunity acc. to EN 61000-6-2

## Applicable directives

2014/30/EU (EMC)

2014/34/EU (ATEX)

# 1.5 Recycling and disposal

Most valve controller parts can be recycled if sorted according to material.

Most parts have material marking. A material list is supplied with the valve controller. In addition, separate recycling and disposal instructions are available from the manufacturer.

A valve controller may also be returned to the manufacturer for recycling and disposal. There will be a charge for this.

# 1.6 Safety precautions

### CAUTION:

Do not exceed the permitted values!

Exceeding the permitted values marked on the valve controller may cause damage to the controller and to equipment attached to the controller and could lead to uncontrolled pressure release in the worst case. Damage to the equipment and personal injury may result.

### CAUTION:

Cover should be opened only in dry places, not when the device is vulnerable to e.g. salt water.

### CAUTION:

Do not remove or dismantle a pressurized controller!  
Removing or dismantling a pressurized prestage or spool valve of an SwitchGuard leads to uncontrolled pressure release. Always shut off the supply air and release the pressure from the pipelines and equipment before removing or dismantling the controller. Otherwise personal injury and damage to equipment may result.

### WARNING:

During calibration and tuning the valve operates between open and closed positions. Make sure that the operation does not endanger people or processes!

### WARNING:

Do not operate the device with the cover removed!  
Electromagnetic immunity is reduced, valve may stroke.

### Ex WARNING:

The locking screw (part 107) of the cover is essential to explosion protection.

The cover has to be locked in place for Ex d protection. The screw grounds the cover to the housing.

### Ex WARNING:

Spark hazard!

Protect the aluminium housing and cover from impacts.

### Ex WARNING:

Electrostatic charge hazard!

The pointer and display windows are non-conductive. Clean with a damp cloth only!

### Ex WARNING:

Electrostatic charge hazard!

The paint of the device can enable charging of the metal parts by high voltage sources. Do not install the device in proximity of high voltage sources!

### Ex i WARNING:

Ensure that the complete installation and wiring is intrinsically safe before operating the device!

### Ex i WARNING:

Do not operate the device with electronics cover (39) removed!

Electromagnetic immunity is reduced, valve may stroke. Ex i: intrinsic safety may be impaired.

### Ex i WARNING:

For intrinsically safe applications, the equipment must be connected via a certified Zener barrier placed outside the hazardous area!

### Ex d NOTE:

Only persons familiar with Ex d explosion protection are allowed to work with the device. Special attention has to be paid to careful handling and closing of the cover.

### Ex d WARNING:

Do not open the cover when an explosive atmosphere may be present!

### Ex d WARNING:

Use a cable gland with suitable Ex d certification.

For ambient temperature over 70 °C / 158 °F use a heat resistant cable and cable gland suitable for at least 90 °C / 194 °F.

### Ex d WARNING:

Any unused conduit entry shall be plugged with an Ex d rated plug.

### ELECTRICAL SAFETY WARNING:

Use fuses for limit switch installations with 50 V AC / 75 V DC or higher.

### NOTE:

Avoid earthing a welding machine in close proximity to an SG9000H valve controller.

Damage to the equipment may result.

### NOTE: (Class I, Division 2):

This equipment is suitable for installation in Class I, Division 2, Groups A, B, C, D hazardous locations or nonhazardous locations only.



**NOTE: (Class I, Division 2):**

Wiring to or from this device, which enters or leaves the system enclosure, must utilize wiring methods suitable for Class I, Division 2 Hazardous Locations, as appropriate for the installation.

**WARNING: Explosion Hazard:**

Do not connect or disconnect this equipment unless power has been removed or the area is known to be nonhazardous.

**WARNING: Explosion Hazard:**

(Class I, Div 2): Substitution of components may impair suitability for Class I, Division 2.

## 2. TRANSPORTATION, RECEPTION AND STORAGE

The on/off controller is a sophisticated instrument, handle it with care.

- Check the controller for any damage that may have occurred during transportation.
- Store the controller preferably indoors, keep it away from rain and dust.
- Do not unpack the device until installing it.
- Do not drop or knock the controller.
- Keep the flow ports and cable glands plugged until installing.
- Follow instructions elsewhere in this manual.

## 3. MOUNTING

### 3.1 General

**NOTE:**

The enclosure of SwitchGuard on/off valve controller meets the IP66 protection class according to EN 60529 in any position when the cable entry is plugged according to IP66. However, it is not allowed to mount the valve controller in position where cable entry is pointing upwards. Based on good mounting practice, the recommended mounting position is electrical connections placed downwards. This recommendation is shown in our mounting position coding for control valves. If these requirements are not fulfilled, and the cable gland is leaking and the leakage is damaging valve controller or other electrical instrumentation, our warranty is not valid.

If the SwitchGuard is supplied with valve and actuator, the tubes are mounted and the SwitchGuard adjusted in accordance with the customer's specifications.

The controller is equipped for connection according to VDI/VDE 3845.

Shaft coupling alternatives for the controller for Neles actuators are shown in Fig. 4.

For mounting parts for Neles actuators, see 10.3 - 10.5.

### 3.2 Mounting on Neles actuators with VDI/VDE mounting face

See figure in Section 10.3.

- Mount the H-shaped coupling (47) to the shaft. Apply the thread-locking compound to the screw (48) and tighten firmly.
- Remove all protective plastic plugs from the pneumatic connections (3 pcs.).
- **BJ and other single acting actuators:** mount a metal plug (53) with sealant to the C1 connection.
- Set the direction arrow of the actuator in the direction of the valve closure member and attach the ear (2) to the indicator cover in the position shown in Section 10.3. Secure the screw of the ear using e.g. Loctite and tighten firmly.
- Attach the bracket (1) to the SwitchGuard.
- Attach the bracket (1) to the actuator. The shaft coupling of the SwitchGuard must fit into the ear (2) so that the pointer is located in the position shown in Fig. 3.

**NOTE:**

Special care must be taken that the shaft position has been set according to marking in SG9000H housing and the pointer in the shaft. Also make sure that the positioner fail action parameter (PFA) is set correctly (Section 4.4.3).

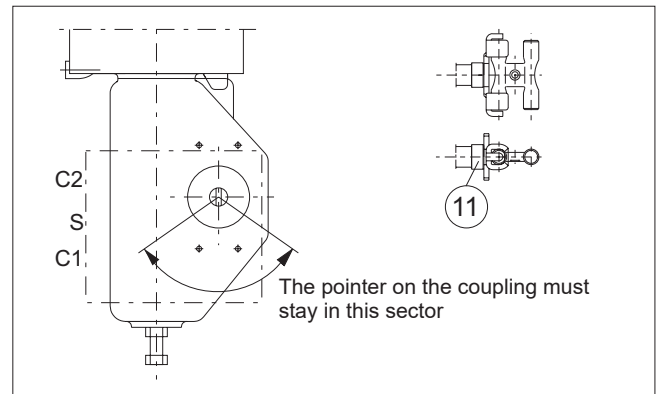

Fig. 3 Mounting on Neles actuator with VDI/VDE mounting face

### 3.3 Mounting on linear actuator with IEC 60534 mounting face

See figure in Section 10.5

- Attach the feedback arm with spacer to the controller shaft. Note the position of the pointer on the shaft as in 10.5. Apply thread locking compound to the screws and tighten firmly. Attach the spring to the feedback arm as shown in Section 10.5.
- Mount the controller mounting bracket loosely to the yoke of the actuator.
- Remove all plastic plugs from all actuator connections (3 pcs.).
- Mount the controller loosely to the mounting bracket guiding the pin on the actuator stem to the slot of the feedback arm.
- Align the bracket and the controller with the actuator stem and adjust their position so that the feedback arm is approximately at a 90° angle to the actuator stem (in the mid-stroke position).
- Tighten the controller mounting bracket screws.
- Adjust the distance of the controller to the pin on the actuator stem so that the pin stays in the lever slot at full stroke. Ensure

also that the maximum angle of the lever does not exceed 45° in either direction. Maximum allowed travel of the lever is shown in Section 10.5. Best control performance is achieved when the feedback lever utilises the maximum allowed angle ( $\pm 45^\circ$  from horizontal position). The whole range should be at least 45°.

- Make sure that the controller is in right angle and tighten all the mounting bolts.
- Ensure that the controller complies with previous steps. Check that the actuator pin does not touch the controller case throughout the entire stroke of the actuator. If the actuator pin is too long it may be cut to size.
- Apply grease (Molykote or equivalent) to the contact surfaces of the actuator pin and the feedback arm to reduce wear.

**NOTE:**

Special care must be taken that the shaft position has been set according to marking in SG9000H housing and the pointer in the shaft. Also make sure that the positioner fail action parameter (PFA) is set correctly (Section 4.4.3).

### 3.4 Mounting and installation of SG9300

**NOTE:**

These instructions are only for the mounting and installation of SG9300, i.e. stainless steel version of SG9000H.

**Mounting bracket**

- Make sure the mounting bracket is suitable for the weight of the device. See detailed weight information in Section 1.5.
- Three extra M8 mounting holes exist in the standard mounting face of the housing for additional support. See dimension drawings for SG9300 in pages 40-41 (Chapter 12). The use of this extra support is mandatory in addition to the standard mounting face.
- There are also two 6.5 mm holes for additional support when needed. See dimension drawings for SG9300 in pages 40-41 (Chapter 12).

**Pipeline support**

- Due to the extra weight of stainless steel version and/or possible heavy vibration, make sure there are proper supports in the pipeline to hold the weight of the valve assembly.

**Spool valve protective cover**

- The spool valve protective cover (454) has 2 pcs. of
- 1/2" NPT threaded openings.
- Openings allow an adequate exhaust capacity and breathing of the spool valve.
- Openings have breathers (456) installed, but they can be replaced with protective piping if needed and when necessary.
- If SG is installed vertically, it is recommended to replace the breather with protective piping in the opening pointing upwards.

**NOTE:**

Breathers should not be plugged or restricted.

**Exhaust adapter**

- The exhaust adapter (8) has a 1/2" NPT threaded opening.
- Opening allows an excess air to be released from the housing and to prevent overpressurization.
- Exhaust adapter has a breather (456) installed, but it can be replaced with protective piping if needed and when necessary.
- Opening in the exhaust adapter shall not be plugged!

**Protective piping**

- Piping of the spool valve cover and/or exhaust adapter shall be done in cases where it is assumed that water can go inside the spool valve cover or into the exhaust adapter in spite of breathers.
- Piping shall be done so that the blowing of the exhaust air is downwards and to prevent water to go inside the protective cover or the exhaust adapter.
- Minimum inside diameter of the piping is 13 mm.
- Exhaust adapter piping shall not be connected to the spool valve cover piping!

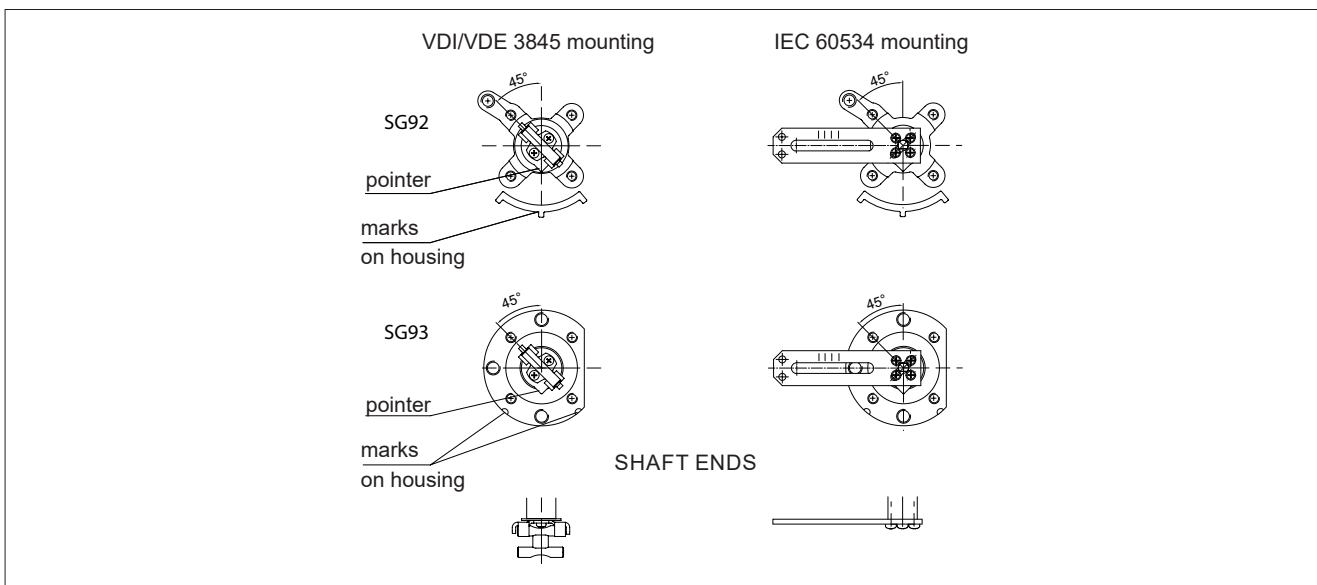

Fig. 4 Shaft coupling alternatives



## 3.5 Piping

**CAUTION:**

Do not exceed the permitted supply pressure of the SwitchGuard!

Table 3 provides the recommended tube sizes in accordance with actuator sizes. Tube sizes are the minimum values allowed.

Connect the air supply to S.

Connect C1 and C2 to the actuator, see Fig. 5. C1 must be plugged if single-acting actuator.

Liquid sealants, such as Loctite 577 are recommended for the pipe threads.

**CAUTION:**

It is important to note, that SwitchGuard mounted on a spring actuator MUST be connected only as single-acting. See Fig. 5.

**NOTE:**

An excess of sealant may result in faulty operation of the controller.

Sealing tape is not recommended.

Ensure that the air piping is clean.

The air supply must be clean, dry and oil-free instrument air, see Section 1.4.

Table 2 Spring rates

Actuator type	Spring rate (bar/psi)
B1JK	3 / 43
B1J	4.2 / 61
B1JV	5.5 / 80
QPX_A	1.4 / 20
QPX_B	2.8 / 41
QPX_C	4.1 / 60
QPX_D	5.5 / 80

Adjust regulator pressure to a level that is max 1 bar (14.5 psi) + spring rate.

**CAUTION:**

Always adjust the maximum valve speed parameter according to Table 3. Erroneous value may cause instability.

**CAUTION:**

Extra pneumatics instrumentation (i.e. QEV, VB, etc.) is not allowed with SwitchGuard when opening and closing stroke profiles are used, i.e. when stroking times are set other than 0 s.

**CAUTION:**

The stroking times mentioned in Table 4 are trendsetting. They are measured with 5 bar supply air pressure, but may vary significantly due to different factors such as, but not limited to, pressure difference of the valve, the stiction of the actuator, supply air pressure, the capacity of the supply air system and the dimensions of the supply air pipeline.

**NOTE:**

When opening/closing times are defined in the Table 3, the specified spool valve size can be used with that actuator size. If there is '-' sign in the table or if smaller actuators than shown in the table are used, please contact Valmet.

**CAUTION:**

The air supply system must be of sufficient size and capacity to ensure that at maximum flow during valve movement the pressure at the SwitchGuard must not fall below 3 bar. Also note that if the air supply system allows the pressure at the SwitchGuard to fall below the actuator minimum supply pressure during valve movement the stroke speed will be affected.

Table 3 Piping, stroke times and maximum valve speed (MAXS) parameter selection

Actuator			SG_12_ Supply 1/4" NPT Actuator 1/4" NPT			SG_15_ Supply 1/4" NPT Actuator 1/4" NPT			SG_35_ Supply 1/2" NPT Actuator 1/2" NPT			SG_37_ (Single acting only) Supply 1/2" NPT Actuator 1" NPT			Maximum Valve Speed Parameter	
B1C	Stroke vol. dm <sup>3</sup> / in <sup>3</sup>		NPT	Piping	Open (s)	Close (s)	Piping	Open (s)	Close (s)	Piping	Open (s)	Close (s)	Piping	Open (s)	Close (s)	
6	0.3	18	1/4	6 mm or 1/4"	See Note 1	See Note 1	-	-	-	-	-	-	-	-	-	FST
9	0.6	37	1/4	6 mm or 1/4"	See Note 1	See Note 1	6 mm or 1/4"	1.0	1.1	-	-	-	-	-	-	FST
11	1.1	67	3/8	10 mm or 3/8"	See Note 1	See Note 1	10 mm or 3/8"	0.7	0.7	-	-	-	-	-	-	FST
13	2.3	140	3/8	10 mm or 3/8"	See Note 1	See Note 1	10 mm or 3/8"	1.3	1.4	-	-	-	-	-	-	STD
17	4.3	262	1/2	10 mm or 3/8"	See Note 1	See Note 1	10 mm or 3/8"	2.0	2.3	-	-	-	-	-	-	STD
20	5.4	330	1/2	-	-	-	10 mm or 3/8"	2.4	2.6	-	-	-	-	-	-	STD
25	10.5	610	1/2	-	-	-	10 mm or 3/8"	4.5	4.9	16 mm or 5/8"	1.3	1.5	-	-	-	FST (SG_35) SLO (SG_15)
32	21	1282	3/4	-	-	-	10 mm or 3/8"	9.4	9.4	16 mm or 5/8"	2.4	2.7	-	-	-	SLO
40	43	2624	3/4	-	-	-	10 mm or 3/8"	19	19	16 mm or 5/8"	4.9	5.6	-	-	-	SLO
50	84	5126	1	-	-	-	10 mm or 3/8"	38	38	16 mm or 5/8"	9.6	11	-	-	-	SLO
60	121	7380	1	-	-	-	10 mm or 3/8"	54	54	16 mm or 5/8"	14	16	-	-	-	SLO
75	189	11500	1	-	-	-	10 mm or 3/8"	85	85	16 mm or 5/8"	22	25	-	-	-	SLO
502	195	11900	1	-	-	-	10 mm or 3/8"	87	87	16 mm or 5/8"	22	25	-	-	-	SLO
602	282	17200	1	-	-	-	10 mm or 3/8"	126	126	16 mm or 5/8"	32	37	-	-	-	SLO
752	441	26900	1	-	-	-	10 mm or 3/8"	197	197	16 mm or 5/8"	50	57	-	-	-	SLO
B1J B1JA	Stroke vol. dm <sup>3</sup> / in <sup>3</sup>		NPT	Piping	Air (s)	Spring (s)	Piping	Air (s)	Spring (s)	Piping	Air (s)	Spring (s)	Piping	Air (s)	Spring (s)	
8	0.9	55	3/8	10 mm or 3/8"	See Note 1	See Note 1	10 mm or 3/8"	0.5	1.0	-	-	-	-	-	-	FST
10	1.8	110	3/8	10 mm or 3/8"	See Note 1	See Note 1	10 mm or 3/8"	0.7	1.4	-	-	-	-	-	-	FST
12	3.6	220	1/2	10 mm or 3/8"	See Note 1	See Note 1	10 mm or 3/8"	1.2	2.7	16 mm or 5/8"	See Note 1	See Note 1	-	-	-	STD
16	6.7	409	1/2	10 mm or 3/8"	See Note 1	See Note 1	10 mm or 3/8"	3.2	4.8	16 mm or 5/8"	0.7	1.3	25 mm or 1"	See Note 1	See Note 1	FST (SG_35) SLO (SG_15)
20	13	793	3/4	-	-	-	10 mm or 3/8"	4.6	9.3	16 mm or 5/8"	1.4	2.6	25 mm or 1"	See Note 1	See Note 1	SLO
25	27	2048	3/4	-	-	-	10 mm or 3/8"	8.9	18	16 mm or 5/8"	2.9	5.4	25 mm or 1"	2.5	2.9	SLO
32	53	3234	1	-	-	-	10 mm or 3/8"	15	38	16 mm or 5/8"	4.9	11	25 mm or 1"	4.3	5.3	SLO
322	106	6468	1	-	-	-	10 mm or 3/8"	31	77	16 mm or 5/8"	9.8	21	25 mm or 1"	8.5	11	SLO
QPX	Stroke vol. dm <sup>3</sup> / in <sup>3</sup>		NPT	Piping	Air (s)	Spring (s)	Piping	Air (s)	Spring (s)	Piping	Air (s)	Spring (s)	Piping	Air (s)	Spring (s)	QPX
1	0.62	38	3/8	10 mm or 3/8"	See Note 1	See Note 1	10 mm or 3/8"	See Note 1	See Note 1	-	-	-	-	-	-	1
2	1.08	66	3/8	10 mm or 3/8"	See Note 1	See Note 1	10 mm or 3/8"	See Note 1	See Note 1	-	-	-	-	-	-	2
3	2.18	133	3/8	10 mm or 3/8"	See Note 1	See Note 1	10 mm or 3/8"	See Note 1	See Note 1	-	-	-	-	-	-	3
4	4.34	265	3/8	10 mm or 3/8"	See Note 1	See Note 1	10 mm or 3/8"	See Note 1	See Note 1	-	-	-	-	-	-	4
5	8.7	531	3/8	-	-	-	10 mm or 3/8"	See Note 1	See Note 1	16 mm or 5/8"	See Note 1	See Note 1	16 mm or 5/8"	See Note 1	See Note 1	5

Note 1: Stroke times to be defined later

### DOUBLE-ACTING ACTUATOR

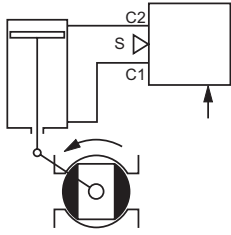

1. Increasing input signal to open valve (shown)

Default setting:  
 DIR = OPE  
 ATYP = 2-A  
 PFA = CLO  
 A0 and VTYP according to valve type

2. Increasing input signal to close valve (**not recommended**)

Default setting:  
 DIR = CLO  
 ATYP = 2-A  
 PFA = CLO  
 A0 and VTYP according to valve type

### DOUBLE-ACTING ACTUATOR, REVERSED PIPING

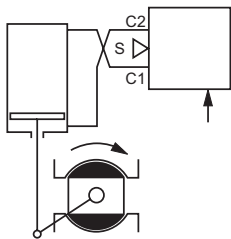

3. Increasing input signal to open valve (**not recommended**)

Default setting:  
 DIR = OPE  
 ATYP = 2-A  
 PFA = OPE  
 A0 and VTYP according to valve type

4. Increasing input signal to open valve (shown)

Default setting:  
 DIR = CLO  
 ATYP = 2-A  
 PFA = OPE  
 A0 and VTYP according to valve type

### SINGLE-ACTING ACTUATOR, SPRING TO CLOSE

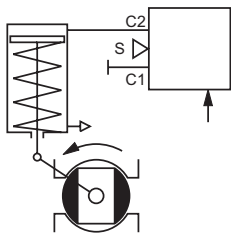

5. Increasing input signal to open valve (shown)

Default setting:  
 DIR = OPE  
 ATYP = 1-A  
 PFA = CLO (must be in the spring direction)  
 A0 and VTYP according to valve type

6. Increasing input signal to close valve (**not recommended**)

Default setting:  
 DIR = CLO  
 ATYP = 1-A  
 PFA = CLO (must be in the spring direction)  
 A0 and VTYP according to valve type

### SINGLE-ACTING ACTUATOR, SPRING TO OPEN

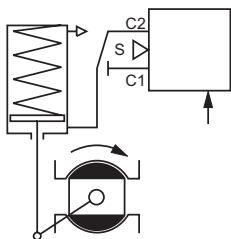

7. Increasing input signal to close valve (shown)

Default setting:  
 DIR = CLO  
 ATYP = 1-A  
 PFA = OPE (must be in the spring direction)  
 A0 and VTYP according to valve type

8. Increasing input signal to open valve (**not recommended**)

Default setting:  
 DIR = OPE  
 ATYP = 1-A  
 PFA = OPE (must be in the spring direction)  
 A0 and VTYP according to valve type

Fig. 5 Operation directions and air connections

### 3.6 Electrical connections

The SG9000H is powered by a standard 4-20 mA current loop that also functions as a carrier to the HART communication.

If a 24 V DC (or up to 230 V AC) output from the control system is used, then an U/I converter is needed as shown in Fig. 7 below. See typocoding in Chapter 14 for different converter options.

The signal cables are led through M20 x 1.5 cable glands.

Cable shall be one or more single-twisted pair shielded or multiple-twisted pair with overall shield. Single and multiple-pair may be combined in a given network provided all current input devices associated with multiple pairs of the same cable shall be located nominally at one end of the multi-pair cable. Unshielded cable may be used if it is demonstrated that ambient noise or crosstalk does not affect communication.

Connect the conductors to the terminal strip as shown in Fig. 6. (Connections '+' and '-').

The optional position transmitter is connected to 2-pole terminal PT as shown in Fig. 6. The position transmitter needs an external power supply. The SwitchGuard and the position transmitter circuits are galvanically isolated and withstand a 30 V DC voltage.

The earthing of the cables shall be carried out at the DCS end only.

**NOTE:**  
The SG9000H equals a load of 485 W in the current loop.

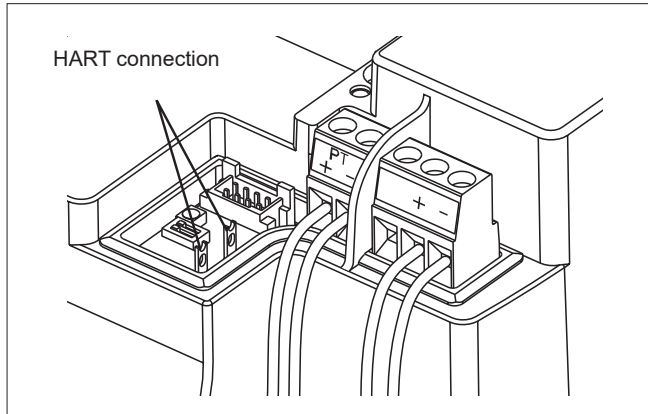

Fig. 6 Terminals when LUI is removed and position transmitter option is in use.

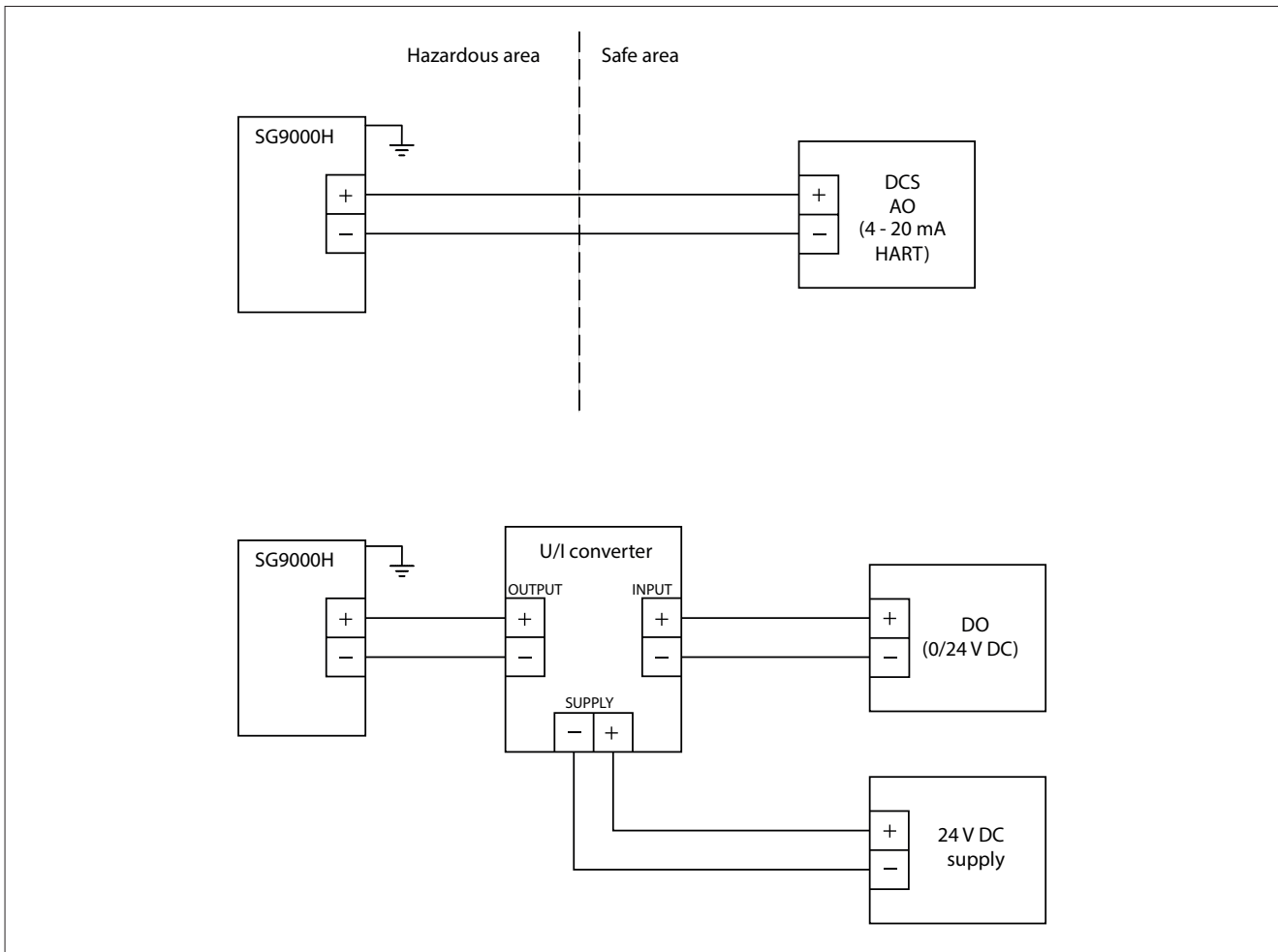

Fig. 7 SG9000H electrical connections with and without U/I converter. See Section 11.6. for other installations.

## 4. LOCAL USER INTERFACE (LUI)

The local user interface may be used to monitor the device behaviour as well as configuring and commissioning the controller during installation and normal operation. The local user interface consists of two row LCD and four button keypad interface. There are also custom graphical characters for special conditions.

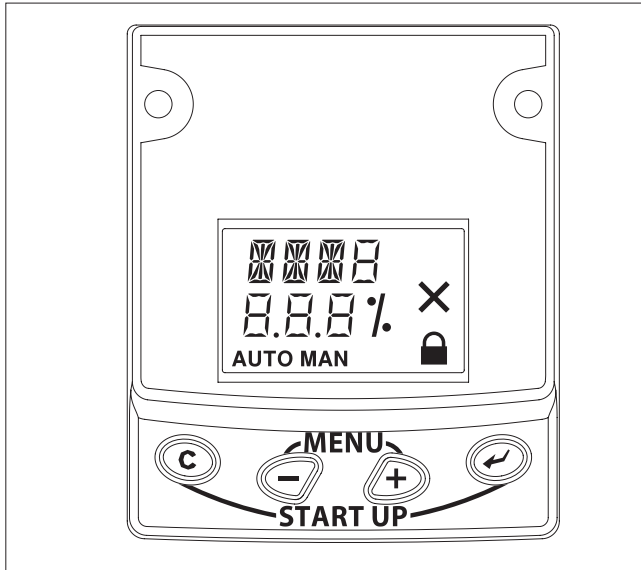

Fig. 8 Local user interface (LUI)

### 4.1 Measurement monitoring

When the device is powered, it enters the measurement monitoring view. The following measurements may be viewed from the display. The Table 4 identifies the default unit and also optional unit of the measurement.

Table 4 Default / optional units of measurements

Measurement	Default unit	Optional unit
valve position	Percentage of full scale	Angle, where 0 % refers to 0 (angle)
current loop setpoint	mA	Percentage of full scale
actuator pressure difference	bar	psi
supply pressure	bar	psi
device temperature	°Celsius (C)	°Fahrenheit (F)

If the unit selection is altered from the FieldCare software to US units, the pressure default unit will automatically be changed to psi and temperature unit to Fahrenheit.

The active unit may be changed by pressing the  $\odot$  key constantly. The display shows the current unit selection on the top row of the display. You may change the selection by pressing  $\oplus$  or  $\ominus$  while keeping the  $\odot$  key pressed down. When the buttons are released the current selection will be activated.

If the device has been idle for 1 hour, and there is no user activity on the local user interface, the measurements will start scrolling on the display. This enables the user to view all the measurements through the window of the main cover.

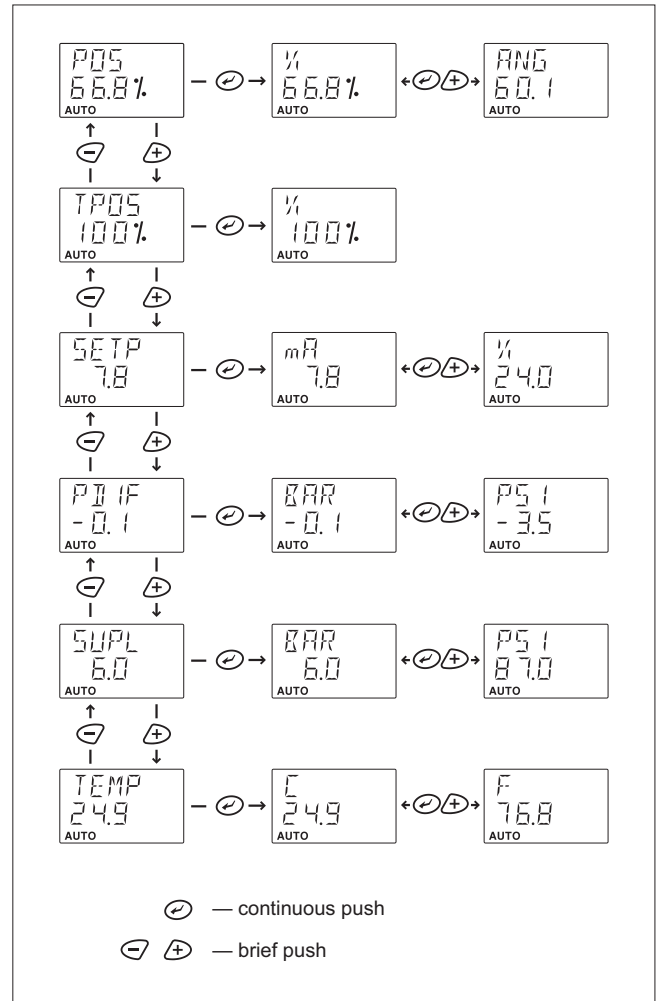

Fig. 9 Measurement unit change

### 4.2 Guided start-up

Guided startup offers a fast view of the most critical parameters of the SwitchGuard controller, actuator and valve configuration. After verifying the parameters the valve travel calibration is recommended. The guided start-up is entered by pressing the  $\odot$  and  $\oplus$  keys simultaneously.

The configuration parameters are listed in following order, see explanation from 4.5:

Valve type	VTYPE
Actuator type	ATYP
Maximum Speed	MAXS
Positioner fail action	PFA
Valve dead angle	A0
Stroke Time Open	STOP
Stroke Time Close	STCL

If you modify any of the parameters you will also need to calibrate and tune the device. See 4.6 for detailed description.

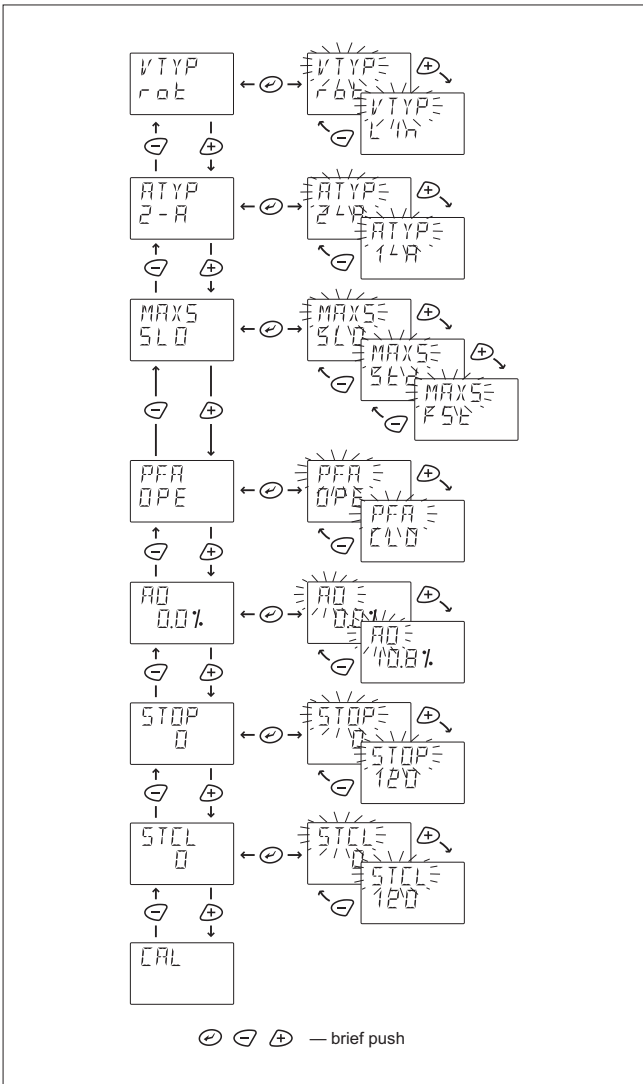

Fig. 10 Guided start-up

**NOTE:**  
 You may cancel any action by pressing the = button.  
 Cancelling of operation returns user interface view one level up in menu hierarchy.

### 4.3 Configuration menu

The local user interface is organised in a menu structure. To enter the menus press  $\rightarrow$  and  $\leftarrow$  simultaneously in the measurement monitoring view panel. To move to the next or previous selection by pressing  $\rightarrow$  or  $\leftarrow$  accordingly.

### 4.4 MODE menu

If the user wants to change the valve operating mode, press the  $\leftarrow$  key at the MODE selection. The mode will start to flash and by pressing  $\rightarrow$  or - you may alter the operation mode selection. User accepts the current selection by pressing the  $\leftarrow$  key.

There are two options for the operating mode.

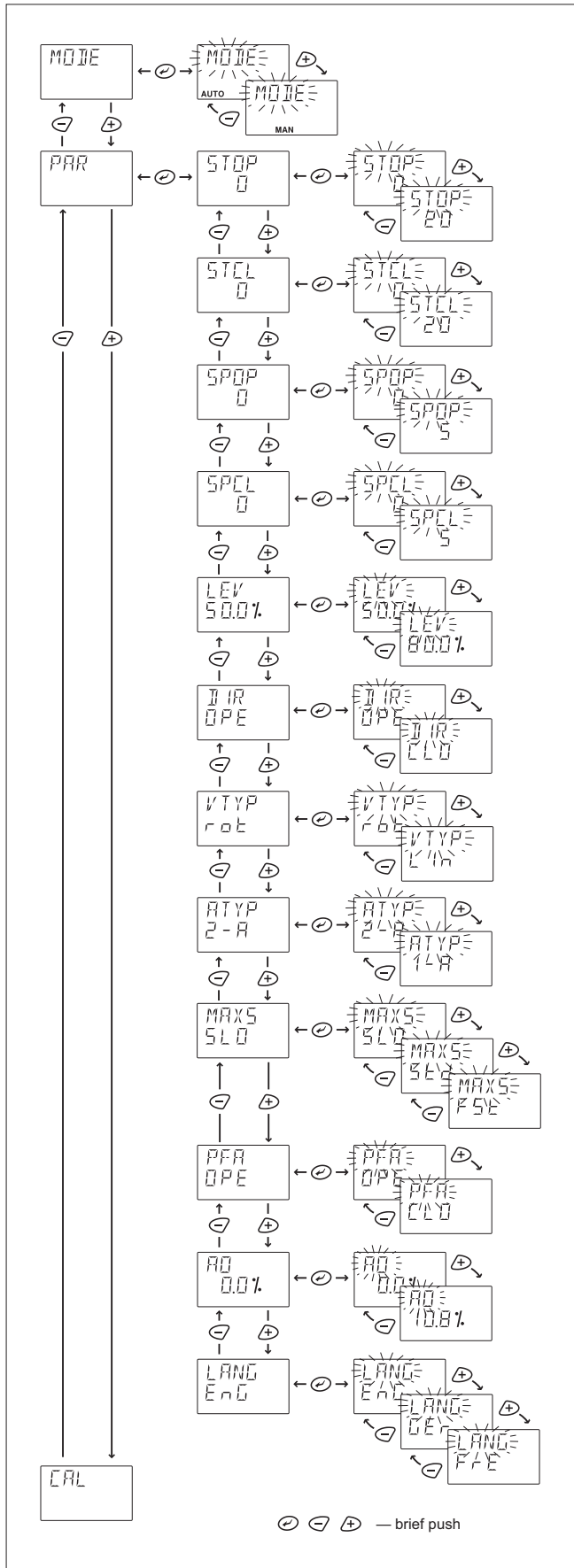

Fig. 11 Configuration



## AUTO

During the AUTO mode, the controller controls the valve position according to the incoming setpoint signal from the 4–20 mA signal source. This mode is used during the normal process control service.

## MAN

It is possible to control the valve position from the keyboard in the Manual Mode. To do this, you must return to Measurement Monitoring Menu (main menu).

- Choose *TP05* and press  $\odot$ . In the upper row *TP05* starts to blink and in the lower row you can see the current position of the valve.
  - CL0* = valve closed
  - OPE* = valve open
  - = valve is somewhere between open and closed positions.
- You can control the valve position as follows:
  - $\oplus$  Opens the valve, "---" blinks during movement.
  - $\ominus$  Closes the valve, "---" blinks during movement.
  - Blinking stops when the valve is again fully open or closed.

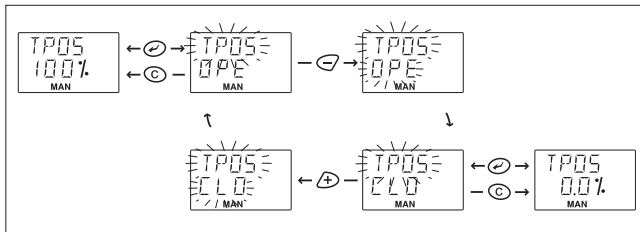

Fig. 12 Setpoint change in MAN mode

## 4.5 Configuration parameters

When *PAR* is on the display you may enter the configuration menu by pressing the  $\odot$  key. In this menu the most important configuration and signal modification parameters are viewable. You may view the current value and edit them by pressing the  $\odot$  key at the relevant parameter. The name of the parameter will appear on the upper row of the display and the current value is on the lower row. See also table in Chapter 13.

### Stroke time and profile, *STOP*, *STCL*, *SPDP*, *SPCL*

Valve open and close profiles can be configured with Neles SwitchGuard with the limitation set by valve assembly. Stroke time performance constraints can be seen from the piping table in Section 3.4. Both stroke directions can be set without any connection to the each other.

Opening and closing times can be set with *STOP* (open) and *STCL* (close) parameters. Parameter is given in seconds.

Used stroke profile shape can be set with parameters *SPDP* (open) and *SPCL* (close). Profile can be chosen separately for both direction from one of the five profile shapes: Linear (1), Slow Starting (2), Slow Starting & Ending (3), Equal Percentage (4) and Quick Starting (5). If valve stroke is needed to do as fast as possible, set time stroke time to 0.

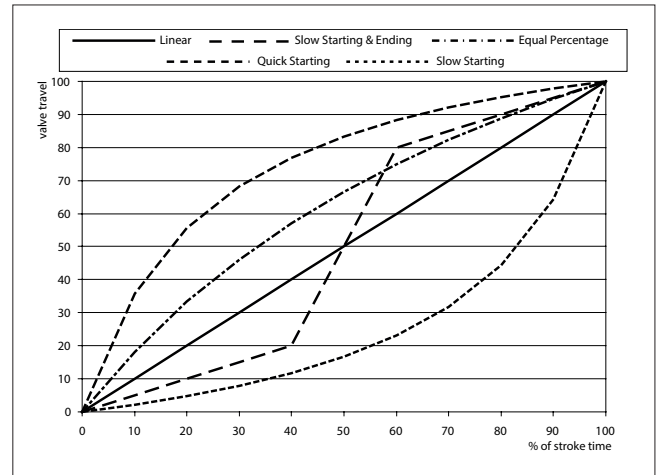

Fig. 13 Stroke profile shapes, opening

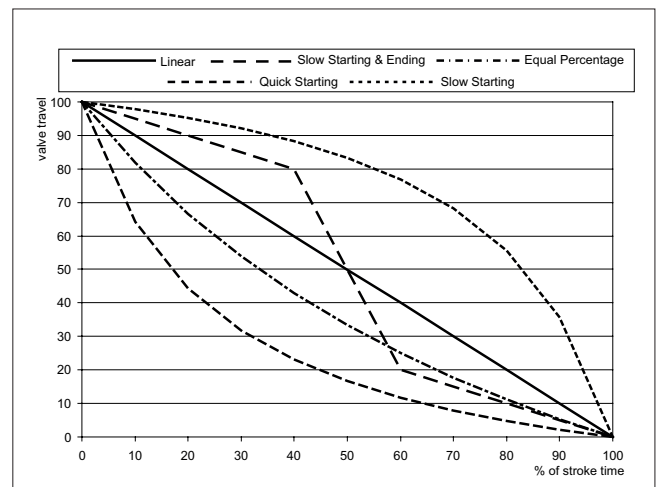

Fig. 14 Stroke profile shapes, closing

### Trigger level, *LEV*

Input setpoint level to start position transition. A fixed hysteresis is applied on this level (trigger level – 5 %). Default value is 50.0 % (12 mA) and range is 20...80 % (7.2 mA...16.8 mA).

### Signal direction, *DIR*

The opening and closing direction of the valve with raising current loop signal is defined by signal direction parameter *DIR*.

- When *DIR* is displayed press the  $\odot$  key to enter the edit state and *DIR* starts to blink.
- Select either the *OPE* or *CL0* values by pressing the  $\oplus$  and  $\ominus$  keys. The value *OPE* signifies the raising signal 4–20 mA to open the valve and *CL0* means the raising signal to close the valve.
- To conclude, press the  $\odot$  key when the desired value is shown on the display.

See default values in Fig. 5.

#### NOTE:

In case of signal direction (DIR) is same than Positioner Fail Action (PFA) 5 mA input signal is recommended as minimum.

## Valve type, *V TYP*

To compensate for nonlinearity of the position feedback caused by the actuator linkage mechanism of a linear control valve, the appropriate selection must be made on the *V TYP* display.

- After selecting *V TYP* on the display, press the  $\odot$  key to enter the edit state and the *V TYP* starts to blink.
- Select between two values *rot* or *Lin* using the  $\rightarrow$  and  $\leftarrow$  keys. The value *rot* indicates a rotary valve and *Lin* a linear valve.
- To conclude press the  $\odot$  key when the desired value is shown on the display.

## Actuator type, *A TYP*

In order to optimise the control performance the device needs to be informed about the actuator type.

- After selecting *A TYP* on the display, press the  $\odot$  key to enter the edit state and *A TYP* starts to blink.
- Select between two values *2-R* or *1-R* using the  $\rightarrow$  and  $\leftarrow$  keys. The value *2-R* indicates a double acting actuator and *1-R* a single acting actuator.
- To conclude press the  $\odot$  key when the desired value is shown on the display.

## Maximum valve speed, *MAXS*

### CAUTION:

Stroke times are defined by parameters *STOP* and *STCL*. Don't try to adjust the speed with *MAXS*.

Maximum Valve Speed parameter does not adjust the speed of the valve. Parameter describes the pneumatic capacity of SwitchGuard when compared to actuator size.

- Once *MAXS* is displayed, press the  $\odot$  key to enter the edit state and the *MAXS* will start blinking.
- You may select between three values by pressing the  $\rightarrow$  or  $\leftarrow$  key. For small actuators select *FST*, medium size actuators *STB* and large size actuators *SLB*. See Table 3 for correct settings.

### CAUTION:

Always adjust the maximum valve speed parameter according to Table 3. Erroneous value may cause instability.

- After the desired value is displayed, press the  $\odot$  key to conclude the operation.

## Positioner fail action, *PFA*

This section describes the function of the actuator.

Set value according to Fig. 5 for double acting actuators. For single acting actuators set value in the spring direction. This action will also take place when the controller software discovers a fatal device failure. See Fig. 5 for correct settings.

- Once *PFA* is displayed, press the  $\odot$  key to enter the edit state and the *PFA* will start blinking.
- You may select between two values by pressing the  $\rightarrow$  or  $\leftarrow$  key. The *CLB* value indicates that the valve ought to be closed in fail action situations. The *OPE* value indicates the valve to be opened in fail action situations.
- After the desired value is displayed, press the key  $\odot$  to conclude the operation.

### NOTE:

In case of signal direction (DIR) is same than positioner fail action (PFA) 5 mA input signal is recommended as minimum.

## Valve dead angle, *AD*

The  $\alpha_0$  setting is made for segment and ball valves. This setting takes into account the "dead angle"  $\alpha_0$  of the valves. The entire signal range is then used for effective valve opening  $90^\circ - \alpha_0$ . Use 0 % as the "dead angle" for the valves, which dead angle is not known.

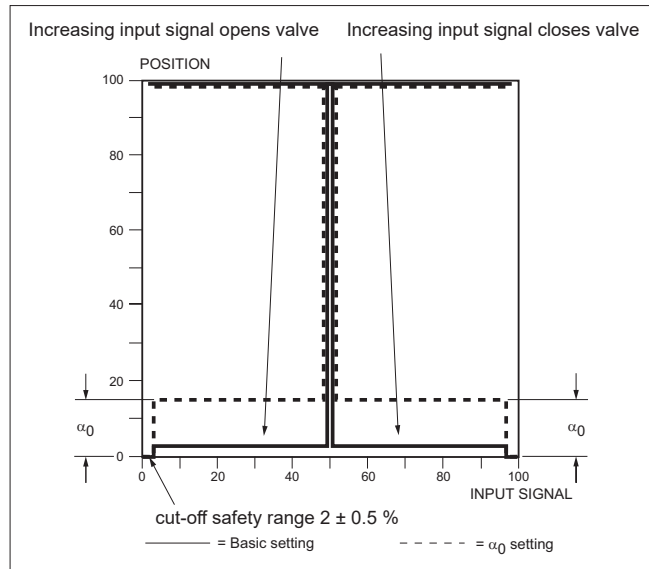

Fig. 15 Principle of setting

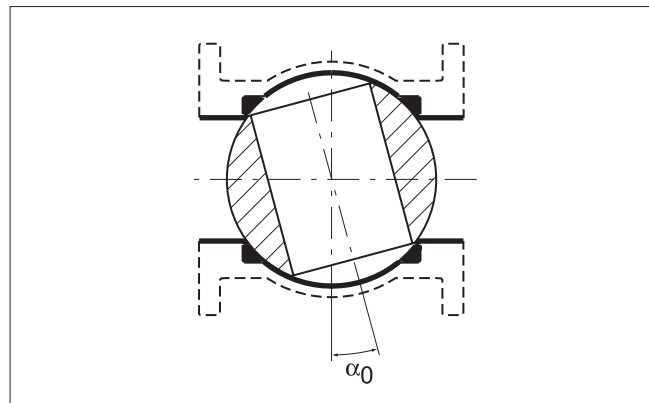

Fig. 16 Dead angle

- After selecting *AD* on the display, press the  $\odot$  key to enter the edit state and *AD* starts to blink. The value currently selected appears as a percentage (%) on the display.
- Modify the parameter value by pressing  $\rightarrow$  or  $\leftarrow$  keys alternately until the desired value appears on the display.
- Press the  $\odot$  key to make your selection and return to the setting state.

## Language selection, *LANG*

- Select between three languages *ENB*, *GBE* or *FRE* (English, German or French) using the  $\rightarrow$  and  $\leftarrow$  keys.
- To conclude press the  $\odot$  key when the desired value is shown on the display.

## 4.6 Valve travel calibration

### NOTE:

Valve travel calibration is possible only when the valve controller is in *AUTO* mode.

Select *CAL* from the menu by using  $\rightarrow$  or  $\leftarrow$  keys and press the  $\odot$  key.

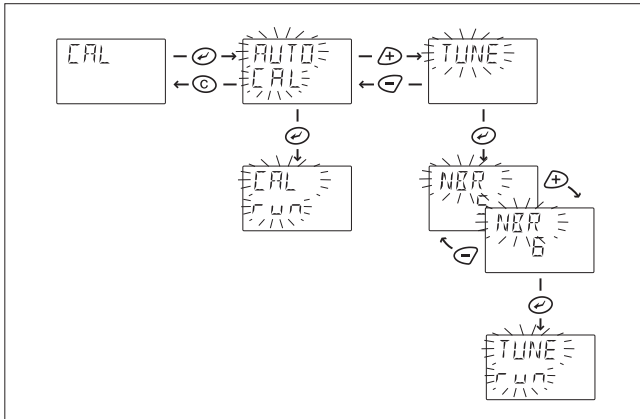

Fig. 17 Calibration selection

### WARNING:

Automatic calibration drives the valve against the mechanical open and closed travel limits of the valve-actuator assembly and a tuning procedure is performed. Make sure that these procedures can be safely executed.

### *AUTO CAL* calibration function

During calibration process a blinking text "*CAL run*" will be show on the display. If calibration ends successfully, a text "*CALIBRATION SUCCESSFUL*" will be shown. Calibration can be cancelled with the  $\odot$  key, which will show a text "*CALIBRATION CANCELLED*". If calibration fails, the reason will be shown, eg. "*CALIBRATION START FAILED*", "*POSITION SENSOR RANGE ERROR*", "*CALIBRATION TIMEOUT*" or "*CALIBRATION FAILED*". After calibration the device will return to the main menu (measurement monitoring).

If the calibration is not finished in 10 minutes, the "*CALIBRATION TIMEOUT*" error is shown.

### *TUNE* Automatic Tuning

After selecting this option the number of strokes will be asked: *NBR 5*.

The user is able to change this number between 2...20. The default value is 5 full strokes (open and close).

- During tuning process a blinking text "*TUNE run*" will be show on the display. If tuning ends successfully, a text "*CALIBRATION SUCCESSFUL*" will be shown. Tuning can be cancelled with the  $\odot$  key, which will show a text "*CALIBRATION CANCELLED*". If tuning fails, the reason will be shown, eg. "*CALIBRATION START FAILED*", "*POSITION SENSOR RANGE ERROR*", "*CALIBRATION TIMEOUT*" or "*CALIBRATION FAILED*". After tuning the device will return to the main menu (measurement monitoring).

### NOTE:

Tuning is only needed if stroke profiles are used, i.e. stroke times are set other than 0 s.

## 4.7 Special displays

### User interface locked

In order to prevent unauthorised access, the Local User Interface may be locked. In this mode measurements may be viewed but configurations and calibrations are prohibited. You may lock and unlock the device via HART or by DIP switch (see 4.8. HART write protection). When the Local User Interface is locked the lock symbol will be activated on the display.

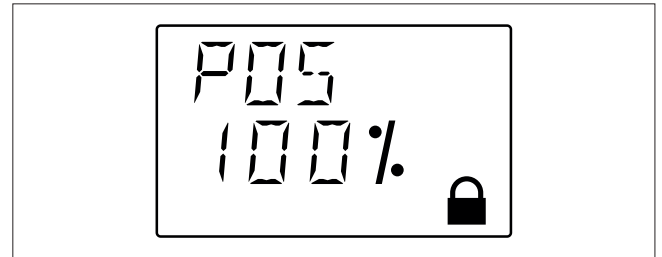

Fig. 18 LUI locked

### Online-alarm active

If an online alarm has been detected the  $\times$  symbol is activated. This symbol will disappear after the recovery from online alarm. You may view the reason for the alarm by viewing the latest event while pushing the  $\odot$  and  $\leftarrow$  keys simultaneously or by using FieldCare software where all events may be viewed.

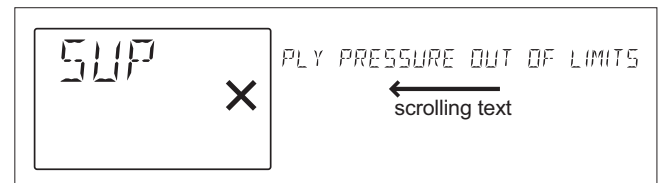

Fig. 19 Online alarm message

### HART Communication active

When double arrow symbol is indicated, HART communication is activated to device.

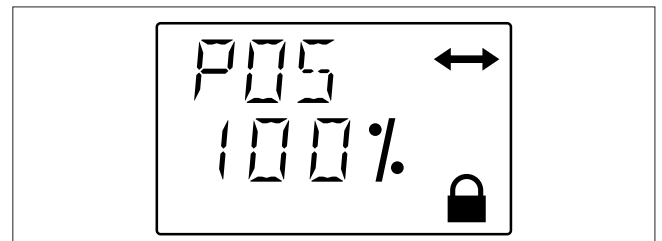

Fig. 20 HART communication activated

### Viewing of latest event

You may view the latest event by pressing the  $\odot$  and  $\leftarrow$  keys simultaneously in the measurement monitoring view. The message is scrolled on the top row of the display twice. You may stop the scrolling by pressing the  $\odot$  key. By pressing the  $\odot$  key, the message will disappear.

For the list of events see Chapter 6.

## Fail-safe active

When the SwitchGuard detects serious device failure (setpoint, valve position and control signals) it enters fail-safe mode, which drives the control valve into the position defined in the parameter controller fail action (*PF*). Fail-safe mode is indicated by the display as seen in Fig 21. The error message is displayed until the cause of error is eliminated and the SwitchGuard unit is restarted, i.e. the power loop is momentarily disconnected.

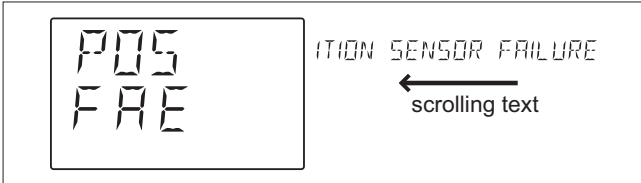

Fig. 21 Failsafe display

## 4.8 HART write protection

The SG9000H is delivered from the factory with the default set as HART write protection OFF. Reading and changing parameters is allowed. HART protection may be enabled with a switch (DIP1) located on the communication circuit board under the Local User Interface module, Fig. 22. Changes that may influence the valve position cannot be made using the FieldCare software or HART hand held when switch no. 1 (on the left-hand side of the switch block) is ON.

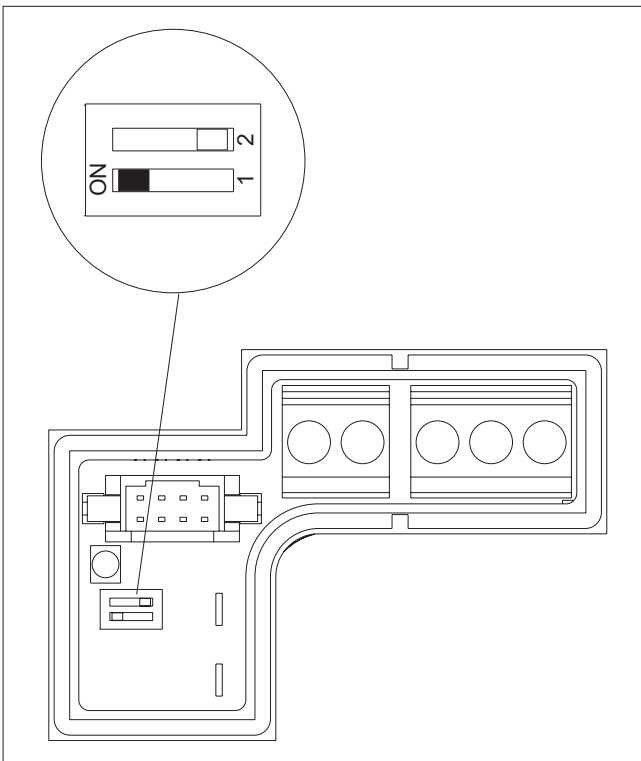

Fig. 22 HART write protection

## 5. MAINTENANCE

### Ex d NOTE:

**Maintenance of the parts of the flameproof enclosure is not allowed!**

Device type SG9000H\_E6\_: Housing (2), Cover (100), Shaft assembly (11), Limit switch housing (300).

The maintenance requirements of the SwitchGuard valve controller depend on the service conditions, for instance, the quality of instrument air. Under normal service conditions there is no requirement for regular maintenance.

When maintaining the SwitchGuard ensure that the supply air is shut off and pressure is released. In the following text the numbers in brackets ( ) correspond to the part numbers in the exploded view as shown in Chapter 11, unless otherwise stated.

The SwitchGuard SG9000H includes the following modules: prestage unit (120), spool valve (420), communication circuit board with optional position transmitter (215) and controller circuit board with position and pressure sensors (210).

The spool valve is located on the bottom side of the device while the other modules are located below the cover 100. In the event of failure the whole module must be changed. The module retrofit must be assembled in a clean, dry environment. On reassembly apply a thread-locking compound (for instance, Loctite 243) and tighten the screws firmly.

### NOTE:

Whenever any maintenance operations have been done for the SG9000H, the device should be calibrated and tuned.

### 5.1 Opening and closing of the cover

- Open SG9000H cover (100) by opening the M4 screw (107) first until it is not anymore attached to the housing (2). Then turn the cover counterclockwise until it can be removed.
- Close the cover (100) in reverse order. Mount it first on top of the housing (2) and then turn it clockwise until threads are tight and the screw (107) is facing the spring (111) in the housing (2). Tighten the M4 screw (107).

### 5.2 Prestage

#### NOTE:

The prestage must be handled carefully. In particular the moving parts of the prestage should not be touched when the inner cover (39) is not in place.

### Removal

- Loosen the M8 stop screw (110) in the position indicator (109) and turn the position indicator from the shaft (11). Remove the inner cover (39) attached with M3 screws (42, 3 pcs.).
- Unplug the prestage wire connector from the connector board (182). Unscrew the M4 screws (139, 2 pcs.) and lift up the prestage unit (120). Remove the O-ring (140).

## Installation

- Place a new O-ring (140) into the groove in the prestage mounting plate (400) and press the prestage into place. Make sure the nozzle is guided into the O-ring properly. The screws guide the prestage body into the correct position. Tighten the screws (139) evenly.
- Push the prestage 2-pole wire connector into the socket on the connector board (182). The wire connector can only be fitted in the correct position. Replace the inner cover (39) and tighten the M3 screws.

## 5.3 Spool valve

### NOTE:

Spool valve cannot be changed in the field.

### NOTE:

If the maintenance operations are needed for the spool valve, it is advised to replace the whole spool valve assembly with a spare unit.

## Restricted and standard

Restricted and standard capacity means the spool valve options 12 and 15 in SG9\_12 and SG9\_15 respectively. See type coding in the machine plate for details.

## Removal

For spool valve removal it is usually necessary to unmount the valve controller from the actuator.

- Before removing the spool valve assembly in SG9300, the spool valve cover (454) needs to be removed. Unscrew the M4 screws (4 pcs.).
- Working from the bottom side of the valve controller, unscrew the M5 screws (4 pcs.). Remove the spool valve (420) with gasket (63). Do not remove the spool valve adapter plate (421).

## Installation

- Mount the spool valve (420) to the housing, and tighten the four M5 screws evenly.
- Mount the spool valve cover (454) (only in SG9300). Tighten the four M4 screws evenly.

### NOTE:

If adapter plate (421) is lifted away from its place, special attention must be paid to ensure that gasket (174) and pipe (431) are properly attached to the housing. O-rings of the pipe must be handled carefully in order to avoid breakage.

## High capacity

High capacity spool valve means the spool valve options 35 or 37 in SG9235 or SG9237. See type coding in the machine plate for details.

## Removal

- Unscrew the M5 screws (4 pcs.). Remove the spool valve (420) with gasket from the mounting block (421).

## Installation

- Ensure that the gasket (63) is properly located in the grooves in the bottom of the spool valve. Mount the spool valve (420) to the mounting block (421), and tighten the four M5 screws evenly.

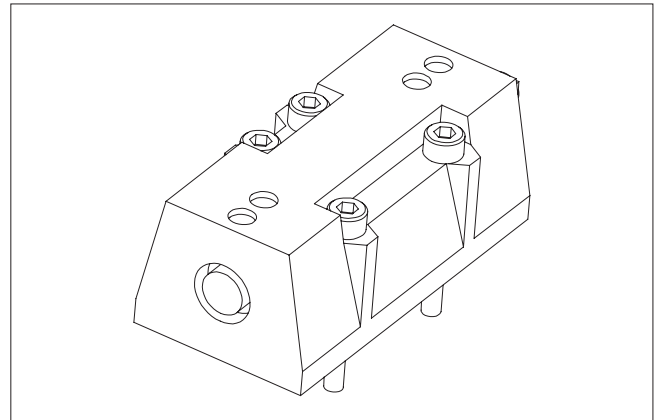

Fig. 23 Spool valve assembly

### NOTE:

If the maintenance operations have been done for the spool valve assembly, the device **must** always be calibrated and tuned.

## 5.4 Communication circuit board

## Removal

- Loosen the M8 stop screw (110) in the position indicator (109) and turn the position indicator from the shaft (11). Remove the inner cover (39) attached with M3 screws (42, 3 pcs.).
- Remove the M3 screws (217, 4 pcs.). Hold the sides of the circuit board and lift it directly upwards and outwards. Handle the board carefully, touching only the sides.

### NOTE:

Ground yourself on the body of the device before touching the circuit board.

## Installation

- Mount the new communication circuit board carefully.
- Locate the pins with the matching connector on the board. Tighten the M3 screws (217) evenly.
- Install the inner cover (39).
- Mount the position indicator (109) on the shaft and tighten the M8 stop screw (110) temporarily. The final orientation and locking of the position indicator should be done after installation of the valve controller to the actuator.

### Ex WARNING:

Grounding of the circuit board is essential to explosion protection.

The board is grounded to the housing by the mounting screw next to the terminal blocks.



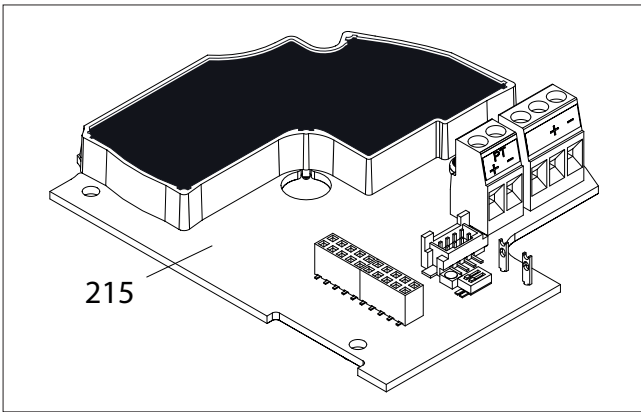

Fig. 24 Communication board

## 6. ERROR MESSAGES

### NOTE:

Parameter limits can only be changed via HART.  
See DTM manual for setting the parameter limits.

### 6.1 Failsafe errors

Display message	Description
CONTINUED INTERNAL BOOT	Too many consecutive internal resets have been generated.
FAILSAFE ACTIVATED	Device is in failsafe state.
PARAMETERS DATABASE ERROR	Parameter database initialization failed.
PRESTAGE SHORTCUT ERROR	Prestage coil shortcut has been detected.
SETPOINT SENSOR ERROR	Setpoint sensor defect has been detected.
SUPPLY PRESSURE FAILSAFE ACTIVATED	Supply pressure has dropped below user defined alarm limit. This causes the device to go to the failsafe state.

### 6.2 Alarms

Display message	Description
PNEUMATICS PROBLEM	Actuator pressure difference has not changed even it should have been. Spool valve may be jammed.
TOO FAST VALVE CLOSING ALARM	Valve was closed faster than was determined by alarm limit parameter.
TOO FAST VALVE OPENING ALARM	Valve was opened faster than was determined by alarm limit parameter.
TOO SLOW VALVE CLOSING ALARM	Valve was closed slower than was determined by alarm limit parameter.
TOO SLOW VALVE OPENING ALARM	Valve was opened slower than was determined by alarm limit parameter.
UNINTENDED VALVE MOVEMENT ALARM	Valve position has changed but setpoint is still in open or close position.
VALVE CLOSE STUCK ALARM	Over 5 % difference between setpoint and valve position. Valve may be jammed at close position. Difference is a user configurable parameter.
VALVE INTERMEDIATE STUCK ALARM	Over 5 % difference between setpoint and valve position. Valve may be stuck between open and close positions. Difference is a user configurable parameter.
VALVE OPEN STUCK ALARM	Over 5 % difference between setpoint and valve position. Valve may be jammed at open position. Difference is a user configurable parameter.

### 6.3 Errors

Display message	Description
CALIBRATION FAILED	Calibration process has failed.
CALIBRATION START FAILED	Calibration process could not be started.
CALIBRATION TIMEOUT	Calibration process has taken too long time.
FACTORY SETTINGS CREATE FAIL	Factory settings creation failed.
FACTORY SETTINGS RESTORE FAIL	Factory settings restoration failed, i.e. current parameter set could not be loaded with factory settings.
INTERNAL BOOT RESET	Software has lost the control and internal watchdog generated reset.
POSITION SENSOR FAILURE	Position sensor defect has been detected.
POSITION SENSOR RANGE ERROR	Too narrow position sensor range was detected in position calibration process.
PRESSURE SENSOR 1 FAILURE	Pressure sensor #1 defect has been detected.
PRESSURE SENSOR 2 FAILURE	Pressure sensor #2 defect has been detected.
PRESSURE SENSOR 3 FAILURE	Pressure sensor #3 defect has been detected.
PRESTAGE CUT ERROR	Prestage coil cut has been detected.
PRESTAGE SHORTCUT ERROR	Prestage coil shortcut has been detected.
PT COMMUNICATION ERROR	Communication with position transmitter was lost.
STATISTICS DATABASE ERROR	Error occurred when writing statistics to database.
TEMPERATURE SENSOR FAILURE	Temperature sensor defect has been detected.

### 6.4 Warnings

Display message	Description
ACTUATOR FULL STROKES WARNING	Actuator full stroke counter has exceeded the warning limit.
CLOSE STROKE DEVIATION WARNING	Valve close stroke deviation time trend has exceeded the warning limit.
OPEN STROKE DEVIATION WARNING	Valve open stroke deviation time trend has exceeded the warning limit.
REDUCED PERFORMANCE ACTIVATED	Controller can not perform boosting due to pressure sensor failure. Also, position sensor failure cause device to act like any normal solenoid device: position can not be controlled.
SPOOL REACTION TIME CLOSE WARNING	Spool valve reaction time close trend has exceeded the warning limit.
SPOOL REACTION TIME OPEN WARNING	Spool valve reaction time open trend has exceeded the warning limit.
SUPPLY PRESSURE OUT OF LIMITS	Supply pressure is out of warning limits.
SUPPLY PRESSURE TREND WARNING	Supply pressure trend value has exceeded the warning limit.
TEMPERATURE OUT OF LIMITS	Temperature is out of warning limits.
TEMPERATURE TREND WARNING	Temperature trend value has exceeded the warning limits.
TOTAL OPERATION TIME WARNING	Total operating time has exceeded the warning limit.
VALVE FULL STROKES WARNING	Valve full stroke count has exceeded the warning limit.
VALVE REACTION TIME CLOSE WARNING	Valve reaction time close trend has exceeded the warning limit.
VALVE REACTION TIME OPEN WARNING	Valve reaction time open trend has exceeded the warning limit.



## 6.5 Notifications

Display message	Description
CALIBRATION CANCELLED	Calibration process has been cancelled.
CALIBRATION SUCCESSFUL	Calibration process has ended successfully.
EXTERNAL RESET	Device has been booted, i.e. power-up reset.
FACTORY DEFAULTS ACTIVATED	Device parameters were changed to factory settings.
REDUCED PERFORMANCE DEACTIVATED	Recovery for reduced performance activation.

## 7. TROUBLE SHOOTING

### Mechanical/electrical defects

- A change in the valve position setpoint will not affect the position of the actuator
  - Supply pressure too low
  - Spool valve sticks
  - Incorrect configuration parameters
  - Actuator and/or valve jammed
  - Signal wires incorrectly connected, no value on display
  - Circuit boards are defective
  - Calibration has not been carried out
  - Device is in manual mode
  - Prestage is defective
  - Device is in fail-safe mode
  - Spool mounted backwards into spool valve
- Inaccurate positioning
  - Spool valve dirty
  - Too high actuator load
  - Supply pressure too low
  - Spool or pressure sensors are defective
  - Actuator leakage
- Overshooting or positioning too slow
  - Spool valve dirty
  - Supply air tube too small or supply air filter dirty
  - Valve sticks
  - Check leakages in tubes between controller and actuator
  - Check leakages in mechanical stop screws
  - Check correctness of MAXS parameter. Change it from "slow" to "fast" or "moderate".
- Error during valve travel calibration
  - Valve controller is in *MAN* mode
  - Check the coupling alignment with the pointer, see Fig. 3
  - The parameter setting *PFR* incorrectly selected
  - The actuator or valve did not move or was stuck during calibration
  - Supply pressure too low
  - Spool valve dirty

## 8. SG9\_H/R\_, SG9\_H/I\_, SG9\_H/K\_ (WITH LIMIT SWITCHES)

### 8.1 Introduction

#### General description

SG9000H can be equipped with limit switches. SG9000H/D\_ has a Dual Module sensor with two inductive proximity switches, SG9000H/R\_ has two reed type proximity switches, SG9000H/I\_ has two inductive proximity switches, SG9000H/K2\_ has two microswitches and SG9000H/K4\_ has four microswitches. Limit switches are used for electrical position indication of the valves and other devices.

The switching points may be chosen freely.

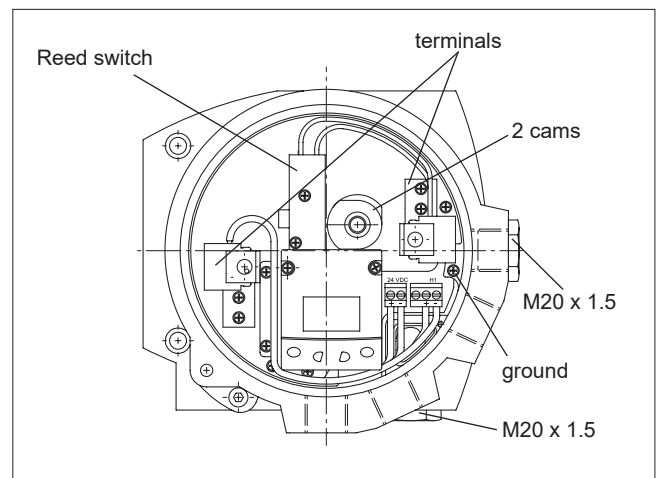

Fig. 25 SG9\_H/R\_ layout

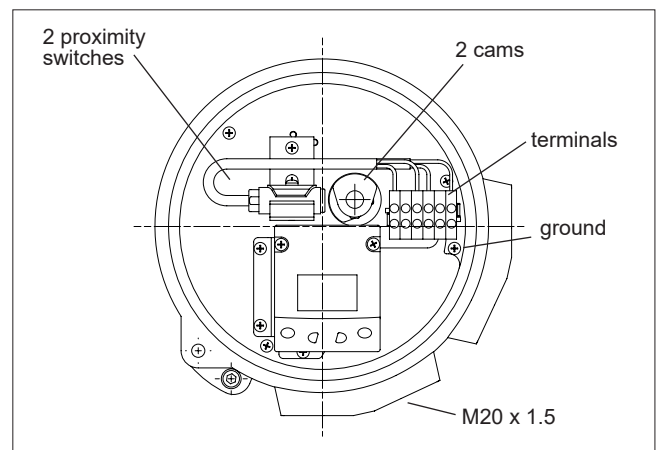

Fig. 26 SG9\_I\_ (I02, I09, I32, I56) layout

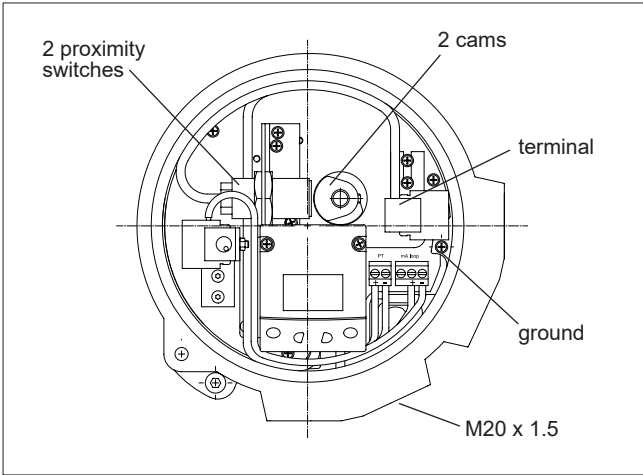

Fig. 27 SG9\_/I45 layout

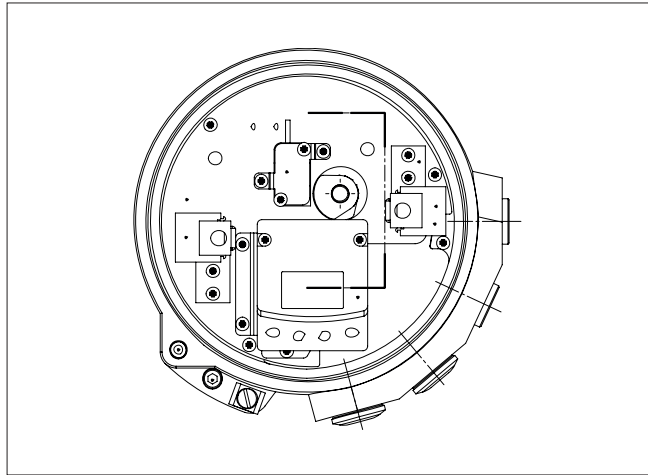

Fig. 30 VG9\_/I57 and \_/I58 layout.

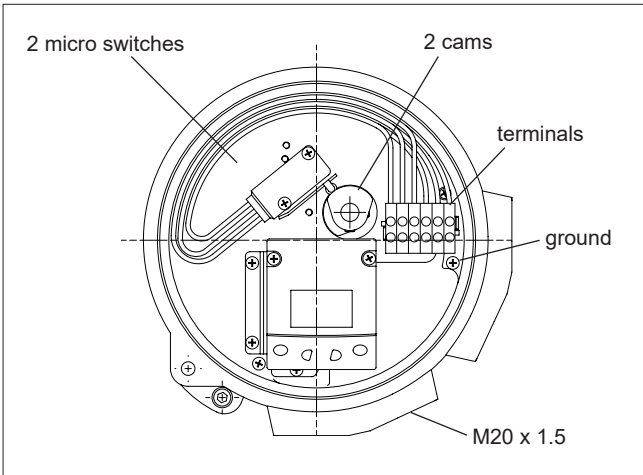

Fig. 28 SG9\_/K2\_ layout

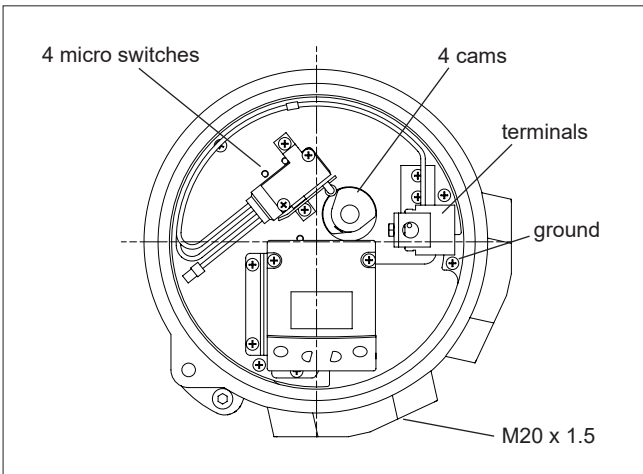

Fig. 29 SG9\_/K4\_ layout

## Markings

The limit switch is provided with an identification plate, see Fig. 32. Identification plate markings include:

- Type designation
- Electrical values
- Temperature range
- Enclosure class
- Conduit entry
- Manufacturing serial number

The type designation is described in Chapter 14.

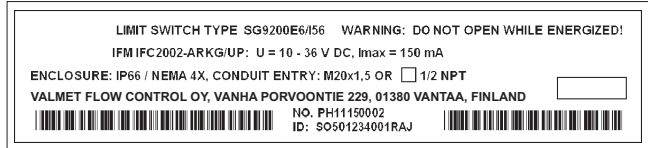

Fig. 31 Example of identification plate

## Technical specifications

### SG9\_H/R\_

Reed switch type:	Valmet MaxxGuard G	(01)
	Valmet MaxxGuard M	(02)
	Valmet MaxxGuard H	(04)
Type:	SPDT	(01, 02, 04)
	Passive, intrinsically safe	(02, 04)
Electrical rating:	300 mA / 24 V DC	(01, 02)
	200 mA / 125 V AC	(01)
	3 A / 240 V	(04)
Max. voltage drop:	0.1 V at 10 mA	
	0.5 V at 100 mA	
Contact:	Rhodium	
Number of switches:	2	(01,02)
SIL:	Usable up to SIL3 acc. to IEC61508	

## SG9\_/I\_

Proximity switch type:	Inductive	
	P+F NJ2-12GK-SN	(02)
	P+F NCB2-12GM35-N0	(09)
	IFM IFC2002-ARKG/UP	(56)
	P+F NJ2-V3-N	(57)
	P+F NJ2-V3-N	(58)
	P+F NJ3-18GK-S1N	(45)
	P+F NCB2-12GM40-E2-3G-3D	(60)
	OMRON E2E-X2Y1	(32)
SIL:	Usable up to SIL3 acc. to IEC61508	(02, 45)
	Usable up to SIL2 acc. to IEC61508	(09, 57, 58)

## SG9\_/K\_

Microswitch type:	OMRON D2VW-5	(25 or 45)
	OMRON D2VW-01	(26 or 46)
	(gold-plated contacts)	
Resistive load:	3A: 250 V AC	(25 or 45)
	5A: 30 V DC	
	0.4A: 125 V DC	
	100 mA: 30 V DC/125 V AC	(26 or 46)
Switch accuracy:	< 2°	
Number of switches:	2	(25 or 26)
	4	(45 or 46)
Ambient temperature:	-40° to +85 °C / -40° to +185 °F	

## Electric data and ambient temperatures

See the certificates.

## 8.2 SG9\_/R\_, SG9\_/I\_ or SG9\_/K\_ on a valve controller

The limit switch may be installed on an existing valve controller.

- If the valve controller is already mounted on an actuator/valve assembly, operate the actuator into the closed or open position.
- Remove the cover (100), the pointer (109), the LUI (223) and electronics cover (39).
- Turn the shaft (311) onto the shaft (11). Fasten the screw (312) using a locking agent such as Loctite.
- Mount the electronics cover (39) and the limit switch housing (300) on the valve controller. Lock the housing in place with screw (326). Install the base plate (324) with the limit switches and connector block into the limit switch housing. Fasten the base plate with screws (325), 3 pcs.
- Install the cam discs (313) and bushings (346) to the shaft.
- Mount the LUI (223) on the holder (306).
- Mount the pointer (109) on the shaft (311). Adjust the limit switch according to 8.4.

## 8.3 Electrical connections

Before connecting the power, make sure that the electrical specifications and the wiring meet the installation conditions. See the diagrams in 10.6. Refer to the information on the identification plate.

**SG9\_/I:** Observe the functioning of the proximity switch; activated when the active face is either covered or free.

## 8.4 Adjustment

The pointer (109) need not be removed for adjustment.

When the limit switch is ordered together with the valve and the actuator, the valve controller switches are factory-adjusted. The limits may be adjusted by altering the position of the cam discs (313) on the shaft. The lower switch is activated at the closed limit and the upper switch at the open limit.

- With the actuator in the open or closed position, locate the switching point by turning the cam disc so that the switch state changes approx. 5°–6° before the limit.

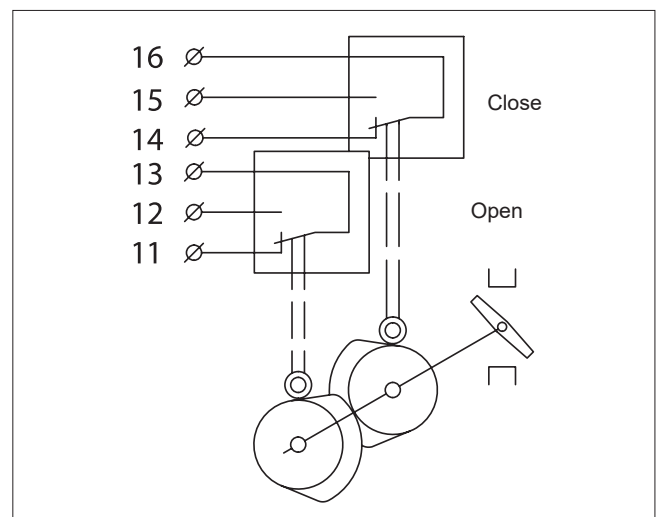

Fig. 32 Limit switch adjustment, 2 switches

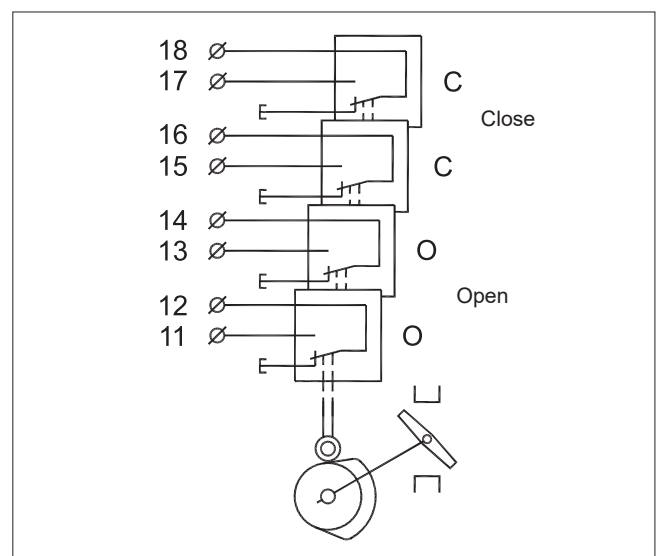

Fig. 33 Limit switch adjustment, 4 switches

- **SG9\_/I:** Use the LED indicator or a separate measuring instrument as an aid.
- After re-installation of the actuator, first adjust its mechanical limits according to the valve, then the valve controller, and finally the limit switch.
- When adjustment is completed, turn the pointer (109) so that the yellow line is parallel with the valve closure member.

## 8.5 Removal of the limit switches SG9\_/R\_, SG9\_/I\_ or SG9\_/K\_ for accessing the valve controller

- Remove the cover (100) and the pointer (109).
- Loosen the screws (314) in the cam disks (313) and remove the cam disks and bushings (346) from the shaft.
- Remove the LUI cabling from the circuit board. Disconnect and remove all cabling which enters the limit switch housing (300).
- Remove screws (325), 3 pcs. and lift out the limit switch base plate (324) complete with switches, LUI and connector block.
- Open screw (326) and turn the limit switch housing (300) from the positioner housing.
- Remove the electronics cover (39).
- Proceed with the valve controller as applicable.
- Re-install the limit switch according to 8.2 and check the adjustment according to 8.4.

### Ex WARNING:

The locking screw of the limit switch housing (Part 326) is essential to explosion protection.

The limit switch housing has to be locked in place for Ex d protection. The screw grounds the limit switch housing to the housing of the valve controller.

## 8.6 Circuit diagrams

The internal circuitry of the limit switch is shown in the connection diagrams in 10.6 and inside the cover.

## 8.7 Maintenance

Regular maintenance of the limit switch is not necessary.

## 9. TOOLS

Following tools are needed for the product installation and service:

- Flat screwdriver  
0.5 x 3.0 x 75 mm
- Torx screwdriver  
T10  
T20
- Hexagon screwdrivers  
3 mm  
6 mm

## 10. ORDERING SPARE PARTS

Spare parts are delivered as modules. The available modules are indicated in 10.1.

When ordering spare parts, always include the following information:

- Type code, sales order number, serial number
- The code of this manual, the part number, the part name and quantity required

This information can be found from the identification plate or documents.

# 11. DRAWINGS AND PARTS LISTS

## 11.1 Exploded view and parts list, SG9000H

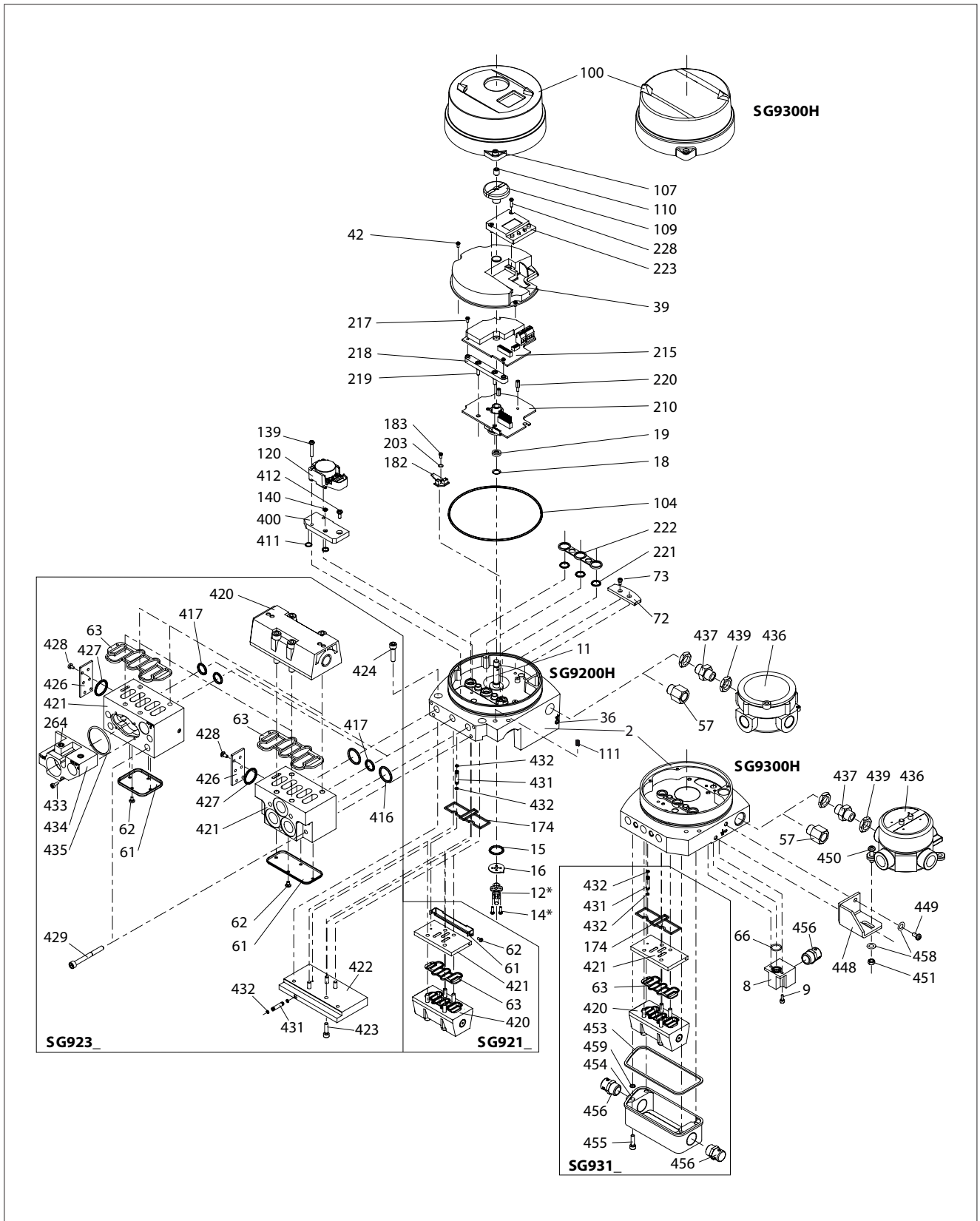

Item	Qty	Description
2	1	Housing
8	1	Exhaust adapter
9	1	Screw
11	1	Shaft assembly
15	1	O-ring
16	1	Washer
18	1	Wave spring
19	1	Bushing
36	1	Grounding screw
39	1	Protection cover
42	3	Screw
57	1	Conduit entry adapter
61	1	Exhaust cover
62	2	Screw (SG9_1_)
	4	Screw (SG923_)
63	1	Gasket
66	1	O-ring
72	1	Cooling plate
73	2	Screw
100	1	Cover
104	1	O-ring
107	1	Screw
109	1	Pointer
110	1	Stop screw
111	1	Spring
120	1	Prestage unit
139	2	Screw
140	1	O-ring
174	1	Gasket
182	1	Prestage board
183	1	Screw
210	1	Controller circuit board
215	1	Communication circuit board
217	4	Screw
218	1	Support
219	2	Screw
220	2	Threaded spacer
221	3	O-ring
222	1	Insulation part
223	1	Local User Interface (LUI)
228	2	Screw
264	2	Plug
400	1	Adapter plate
411	2	O-ring
412	1	Screw
416	2	O-ring
417	1	O-ring
420	1	Spool valve
421	1	Adapter plate
422	1	Adapter plate
423	4	Screw
424	2	Screw
426	1	Plate
427	1	O-ring
428	6	Screw
429	4	Screw
431	2	Connection pipe
432	4	O-ring
433	4	Screw
434	1	Gauge block
435	1	O-ring
436	1	Connection box
437	1	Nipple
439	2	Nut
448	1	Bracket
449	2	Screw
450	1	Screw
451	1	Hexagon nut
453	1	Gasket
454	1	Protection cover
455	4	Screw
456	2 or 3	Breather
458	3	Washer

AVAILABLE SPARE PART SETS:

- LUI (Local User Interface)
- Pointer
- Cover
- Limit switches
- Breather



## 11.2 Exploded view and parts list, SG9\_/R\_, SG9\_/I\_, SG9\_/K\_

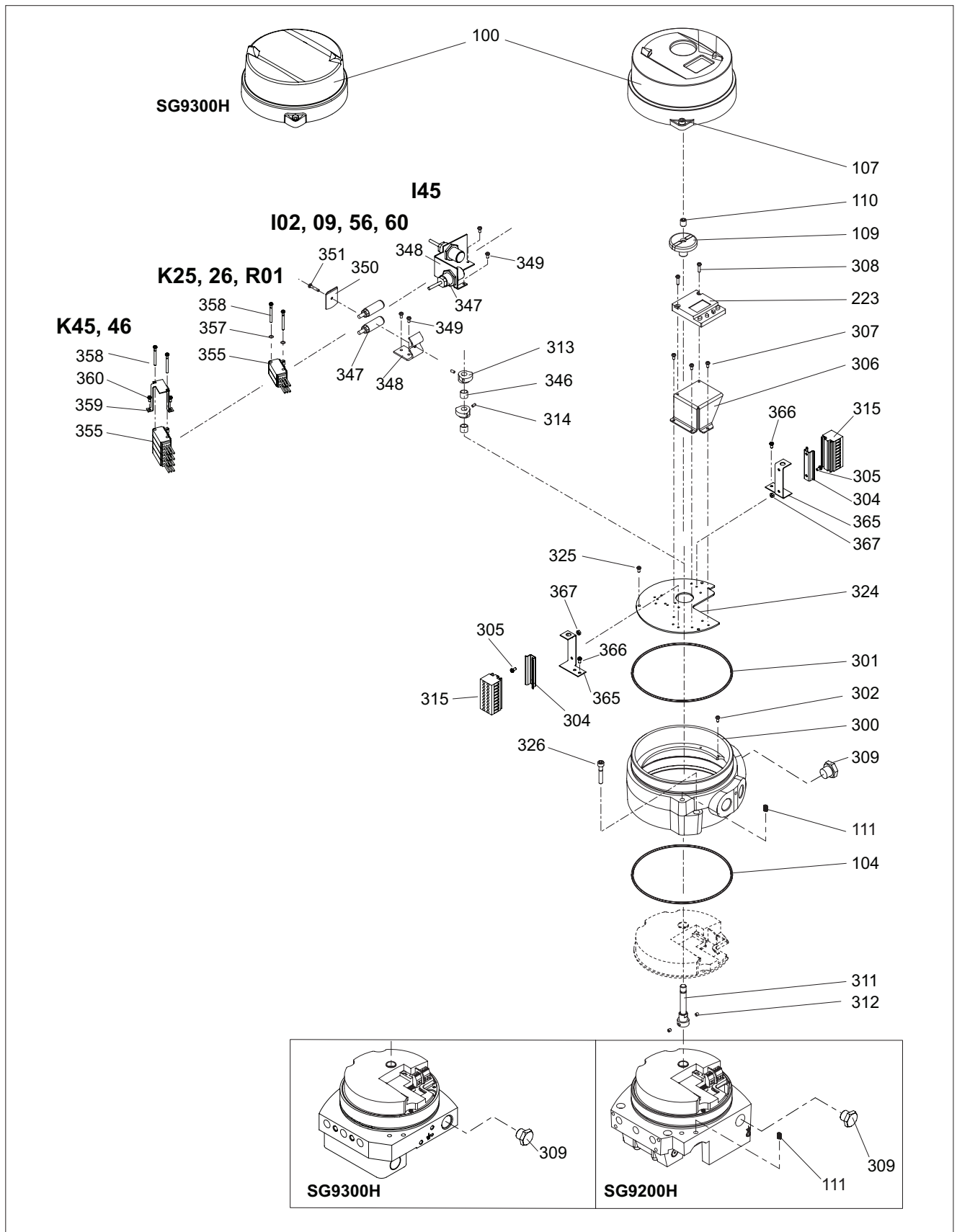

Item	Qty	Description	
100	1	Cover	
107	1	Screw	
109	1	Pointer	
110	1	Stop screw	
111	2	Spring	
223	1	Local user interface (LUI)	
300	1	Housing	
301	1	O-ring	
302	1	Screw	
304	2	Bracket	
305	4	Screw	
306	1	Bracket	
307	3	Screw	
308	2	Screw	
309	2	Plug	
311	1	Extension shaft	
312	2	Screw	
313	2 or 4	Cam disc	
314	2 or 4	Screw	
315	2	Terminal block	
322	1	Proximity switch	
323	2	Screw	
324	1	Base plate	
325	2	Screw	
326	1	Screw	
346	1 or 2	Bushing	
347	2	Proximity switch	
348	1	Fixing plate	
349	2	Screw	
350	1	Washer	
351	1	Screw	
355	2 or 4	Microswitch	
357	2	Spring washer	
358	2	Screw	
359	1	Support band	
360	2	Screw	
365	2	Bracket	
366	4	Screw	
367	4	Hex nut	
449	2	Screw	
450	1	Screw	
451	1	Hexagon nut	

### 11.3 Mounting parts for Neles actuators with VDI/VDE mounting face

Item	Qty	Description
1	1	Mounting bracket
2	1	Ear
3	2	Washer
4	2	Screw
13	4	Screw
14	4	Hexagon nut
28	4	Screw
29	1	Screw
36	1	Couplings jacket
47	1	Coupler socket
48	2	Screw
53	1	Plug (BJ actuators only)

### 11.4 Mounting parts for Quadra-Powr® actuators

Item	Qty	Description
1	1	Mounting bracket
2	1	Ear
4	4	Screw
28	4	Screw
29	1	Screw
30	4	Screw
35	1	Adapter plug (QP II 1/S- 6/S only)
35	1	Adapter plate (QP II 2B/K thr. 6_/K)
36	1	Couplings jacket
47	1	Coupler socket
48	2	Screw
53	1	Plug

Item	Qty	Description
1	1	Mounting bracket
2	2	Coupling half
3	1	Adapter
4	4	Screw
5	4	Hex nut
6	1	Screw
7	4	Screw
8	4	Washer
9	4	Screw
10	4	Washer
47	1	Coupler socket
48	2	Screw
53	1	Plug

## 11.5 Mounting parts for linear actuators

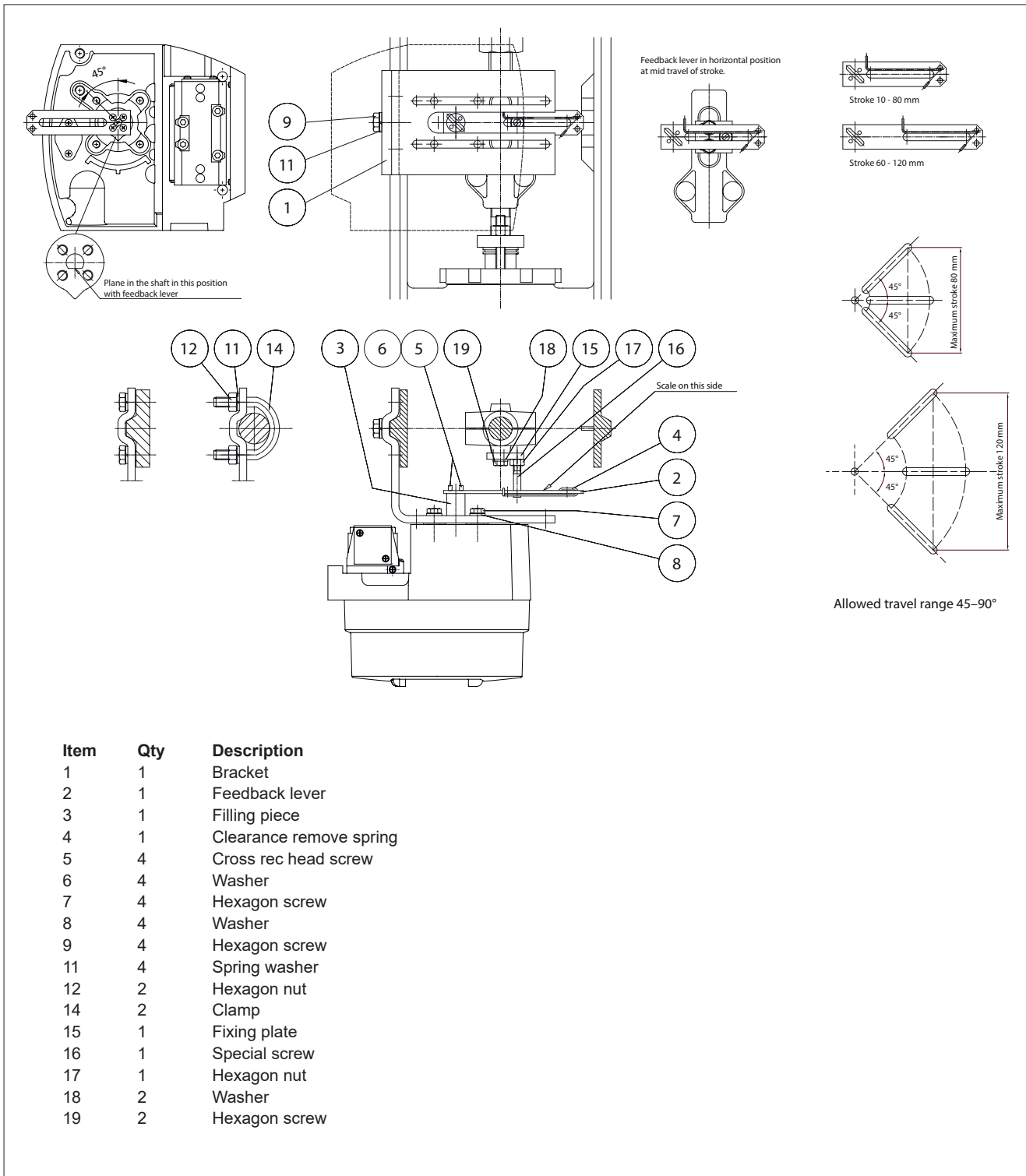

## 11.6 Connection diagrams

See Section 8.1.3 for additional limit switch data.

### SG9\_H/R01, R02, R04

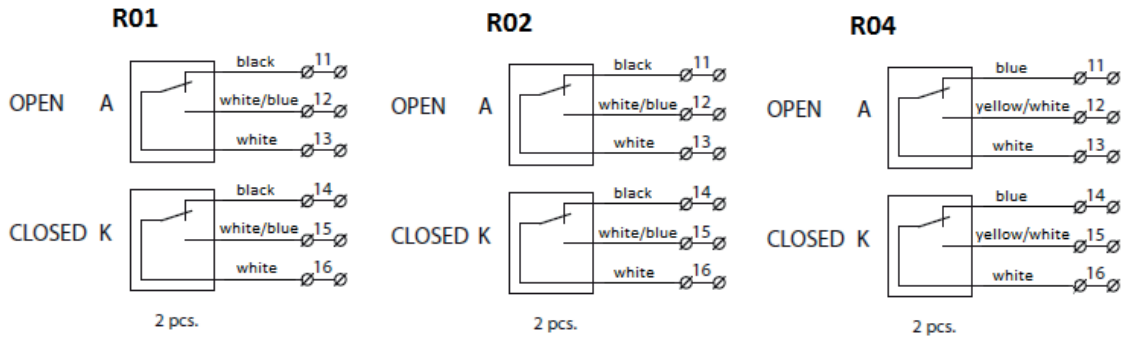

#### Factory adjustment

Connection diagram shows limit switch when actuator is in intermediate position.

Switch A (upper) is activated at the open limit of the travel and switch K (lower) at the closed limit.

See Section 8.1.3.2 for electrical ratings.

### SG9\_H/R35

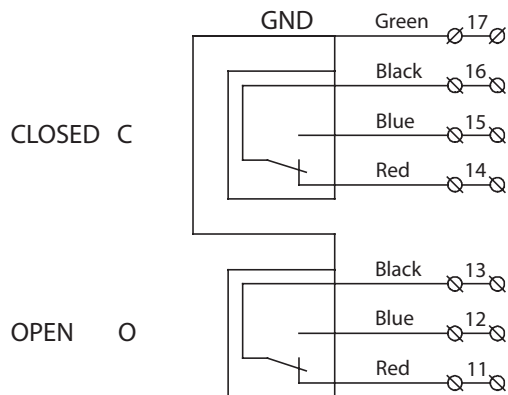

#### Factory adjustment

Connection diagram shows limit switch when actuator is in intermediate position.

Switch C (upper) is activated at the closed limit of the travel and switch O (lower) at the open limit.

Electrical characteristics:

4A - 120 V AC, 2 A - 240 V AC, 3 A - 24 V DC, 0.5 A - 125 V DC

Ambient temperature: -40... + 85 °C

### SG9\_H/102, 109

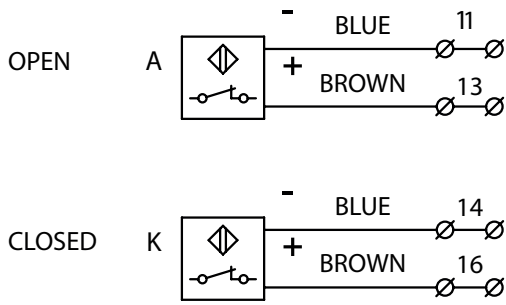

### SG9\_H/145

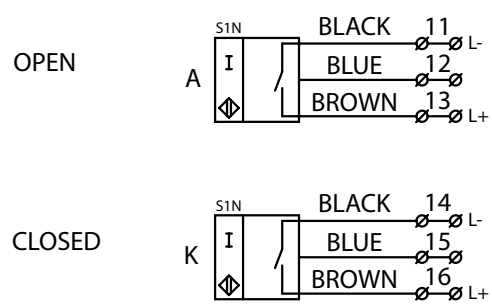

#### Factory adjustment

Active faces of proximity switches are covered when actuator is in intermediate position.  
 Active face A (upper switch) becomes free at open limit of travel and face K (lower switch) at closed limit.  
 Function can be inverted on site by re-adjusting the cam discs.

### SG9\_H/132

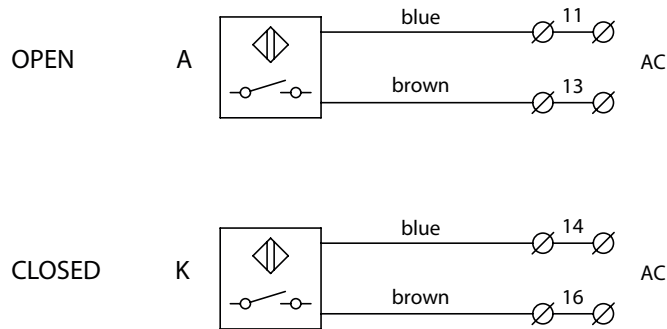

#### Factory adjustment

Active faces of proximity switches are free when actuator is in intermediate position.  
 Active face A (upper switch) becomes covered at open limit of travel and face K (lower switch) at closed limit.  
 Function can be inverted on site by re-adjusting the cam discs.

### SG9\_/160

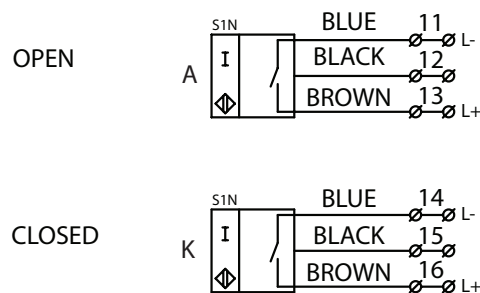

#### Factory adjustment

Active faces of proximity switches are free when actuator is in intermediate position.  
 Active face A (upper switch) becomes covered at open limit of travel and face K (lower switch) at closed limit.  
 Function can be inverted on site by re-adjusting the cam discs.

### SG9\_H/I56

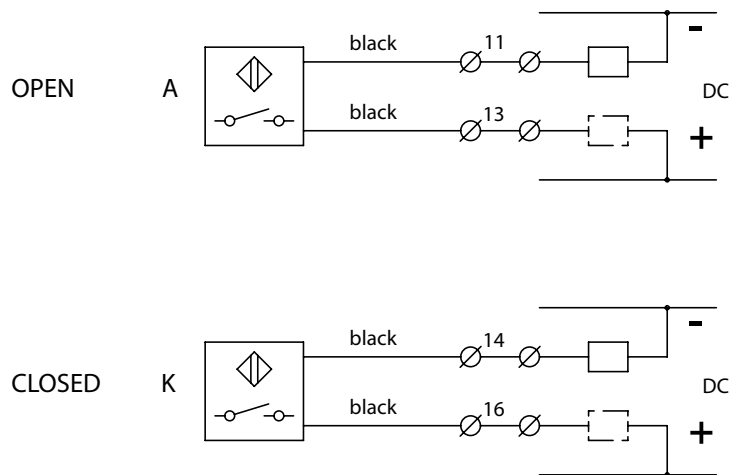

#### Factory adjustment

Active faces of proximity switches are free when actuator is in intermediate position.

Active face A (upper switch) becomes covered at open limit of travel and face K (lower switch) at closed limit.

Function can be inverted on site by re-adjusting the cam discs.

Connections: Load can be connected to + or -.

### SG9\_H/K25, K26, K45, K46

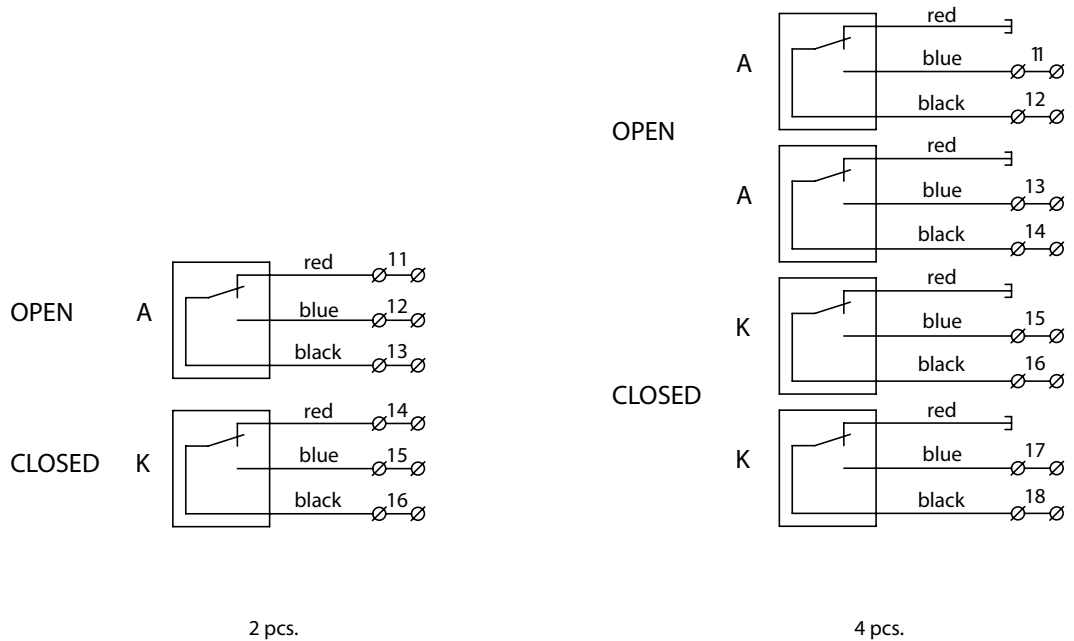

#### Factory adjustment

Connection diagram shows limit switch when actuator is in intermediate position.

Switch A (upper) is activated at the open limit of the travel and switch K (lower) at the closed limit.



SG9\_H\_J

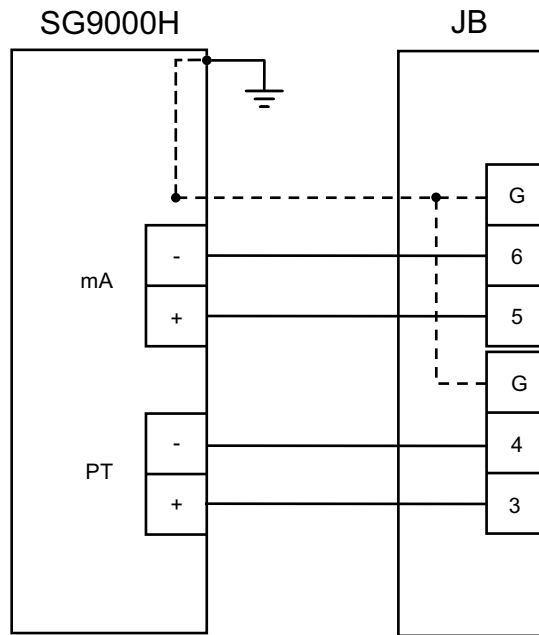

**NOTE:**

Junction box conduit entries are M20x1.5, suitable cable glands shall be used.

**NOTE:**

All unused terminals in the junction box shall be tightened.

**NOTE:**

When External Junction box is used, the external thread types other than metric or metric to NPT converter are not permitted as an option for cable glands in field wiring installations in the junction box. Therefore the user shall ensure that no such cable glands are installed in the enclosure entries.

**NOTE:**

The maximum temperature at the cable entry and branching point is 80.9°C at a maximum ambient temperature of 80°C. This shall be considered for determining the cable or cable entries during installation.

## 12. CONTROL DRAWINGS

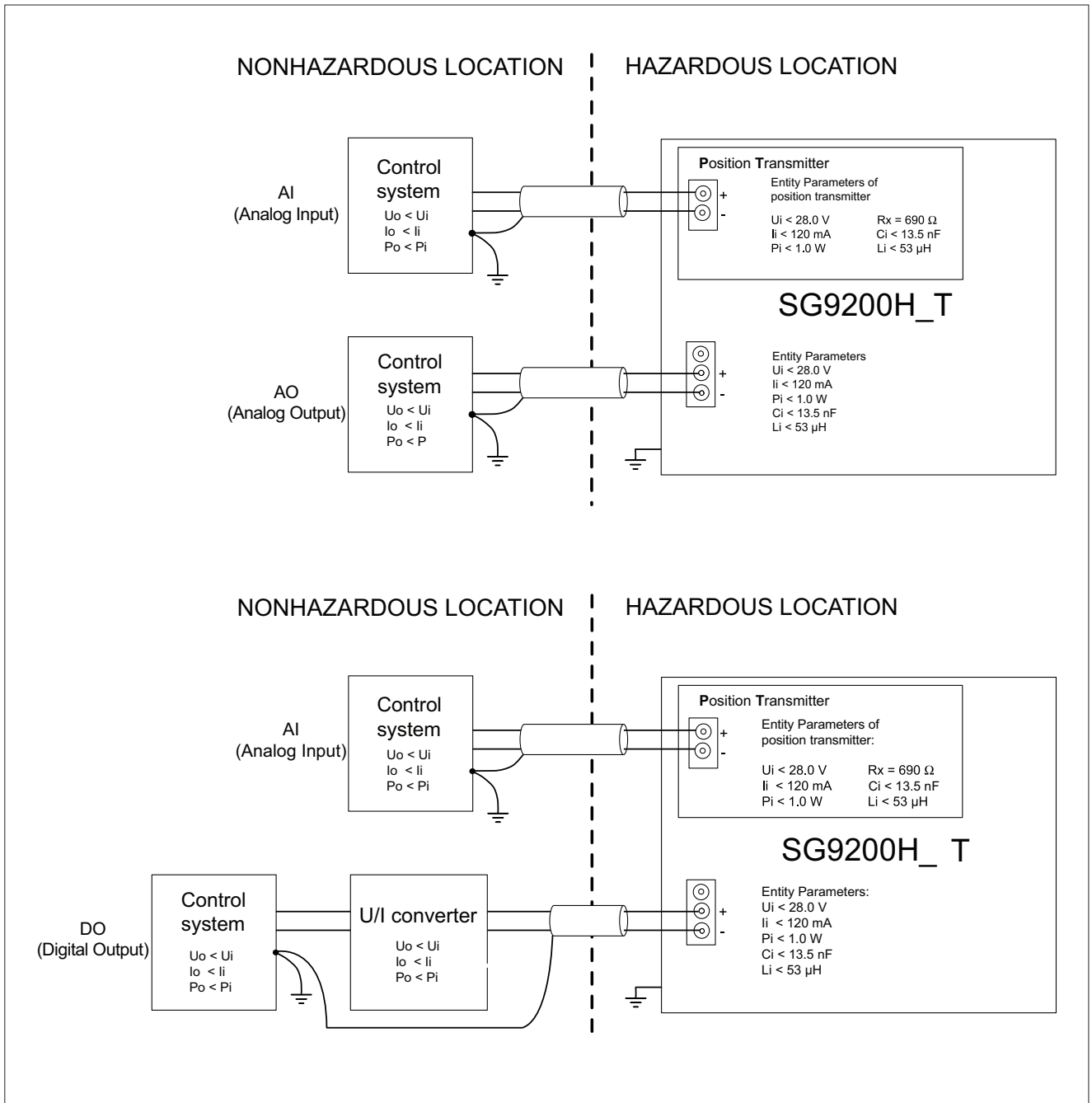

# 13. DIMENSIONS

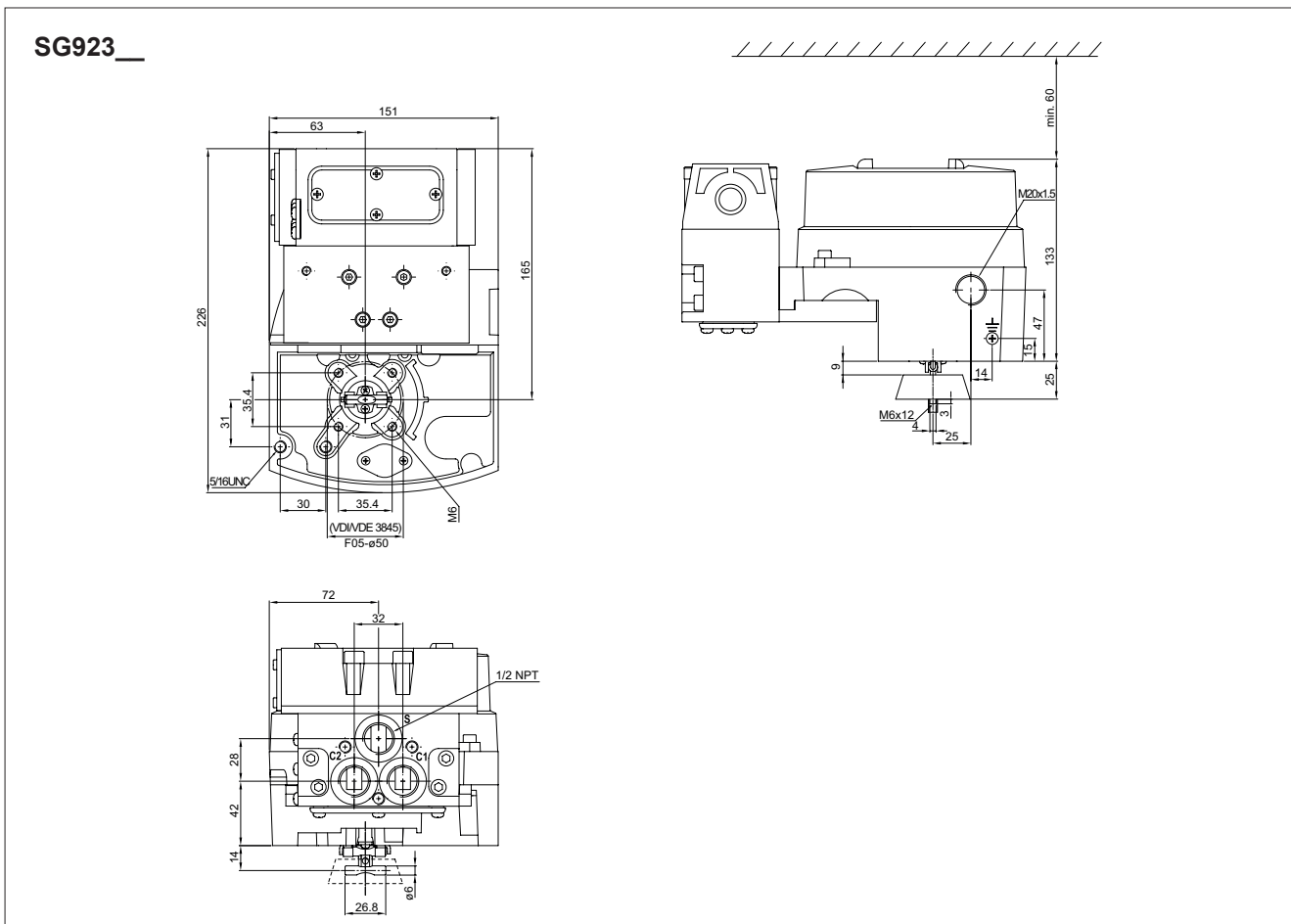
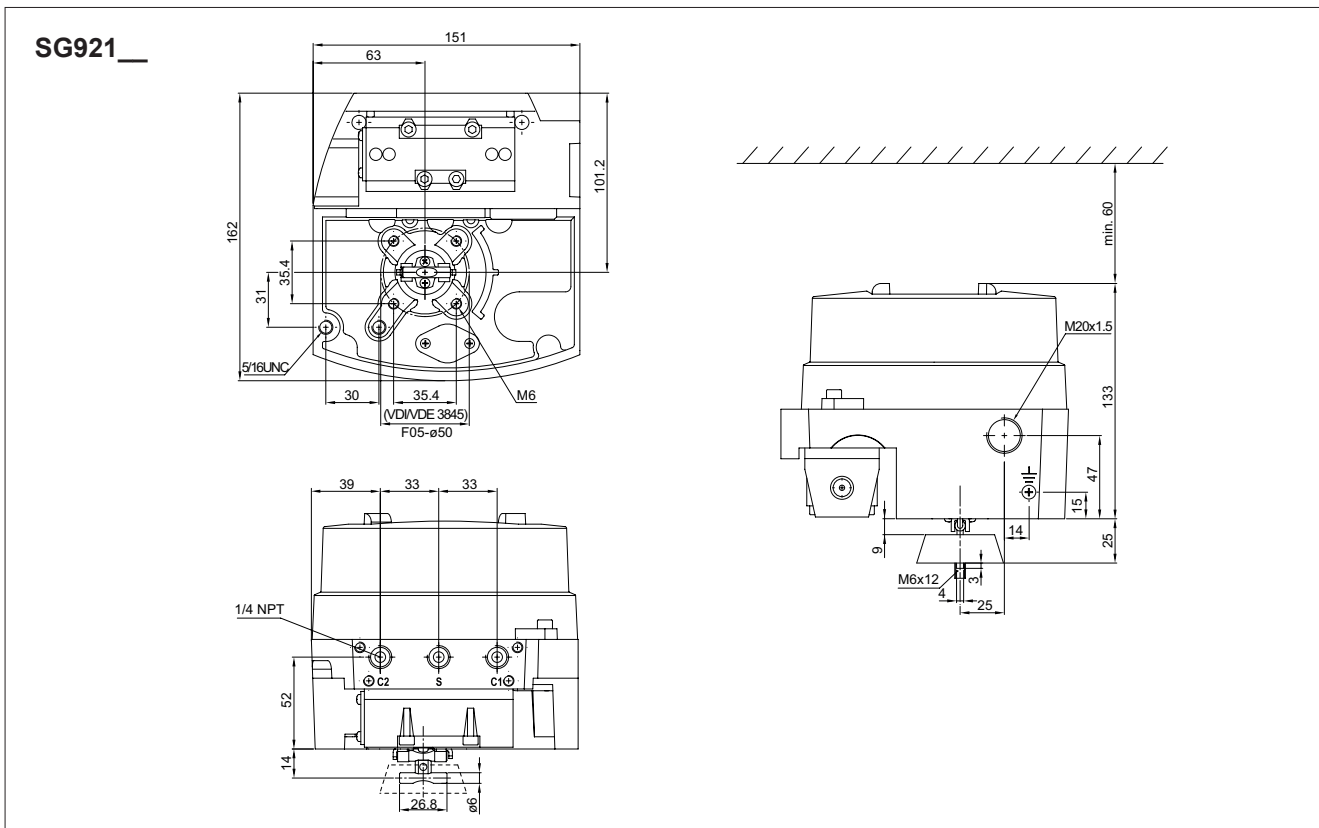

### SG921\_J

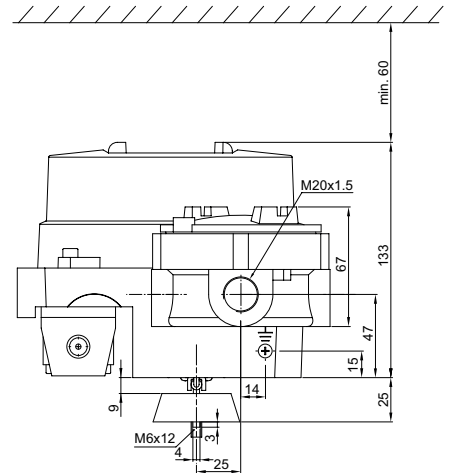
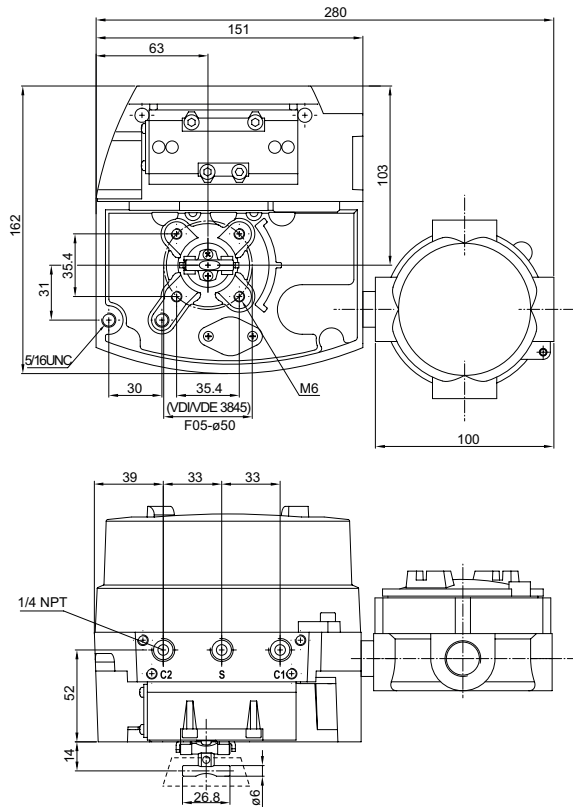

### SG923\_J

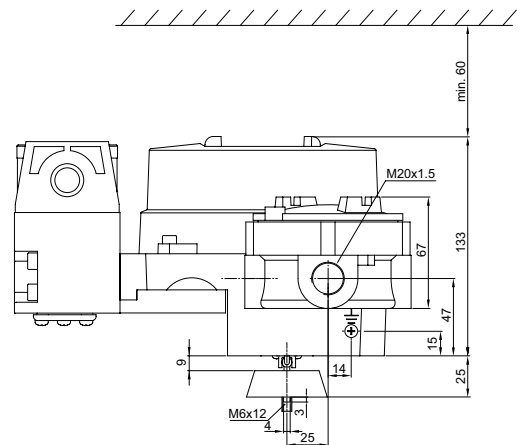
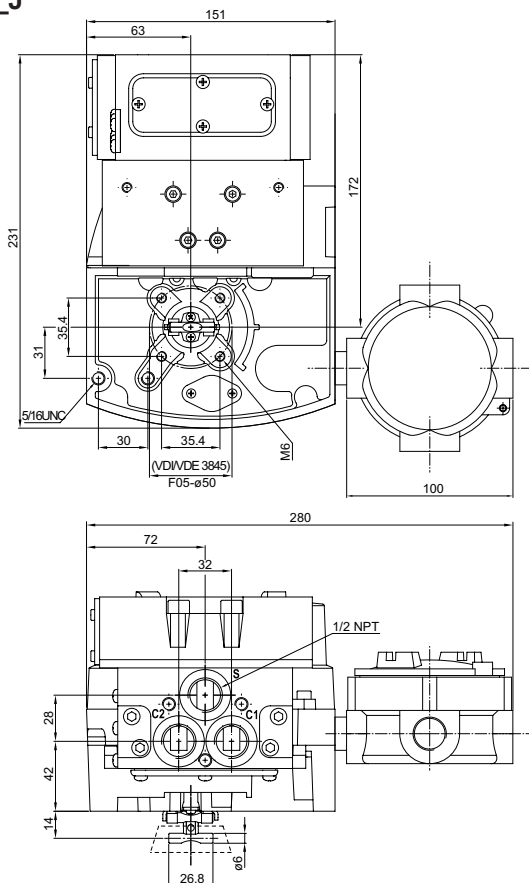

### SG921\_ with limit switches

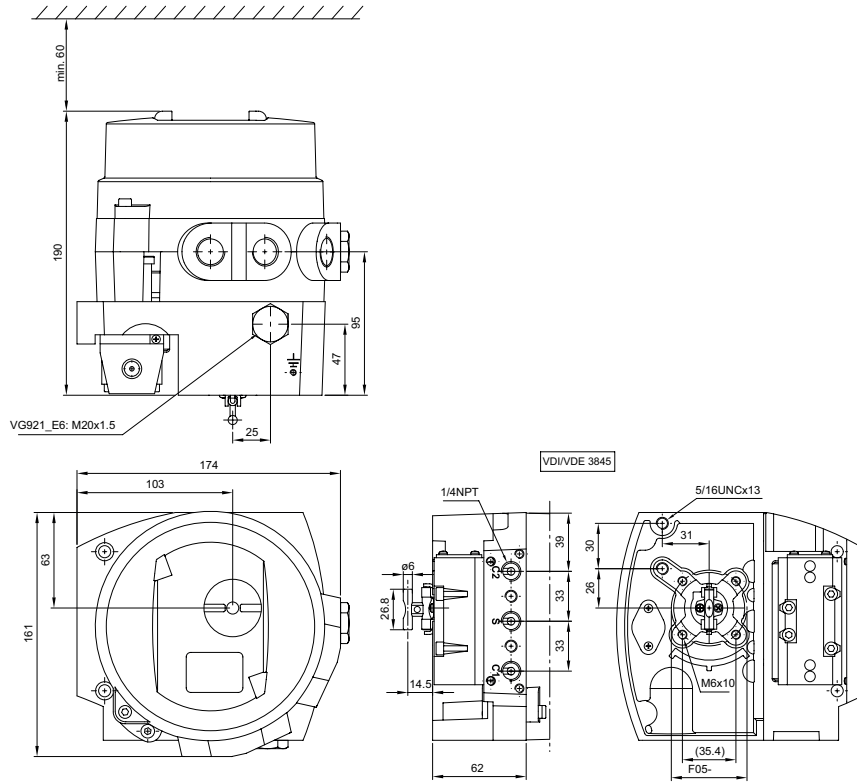

### SG923\_ with limit switches

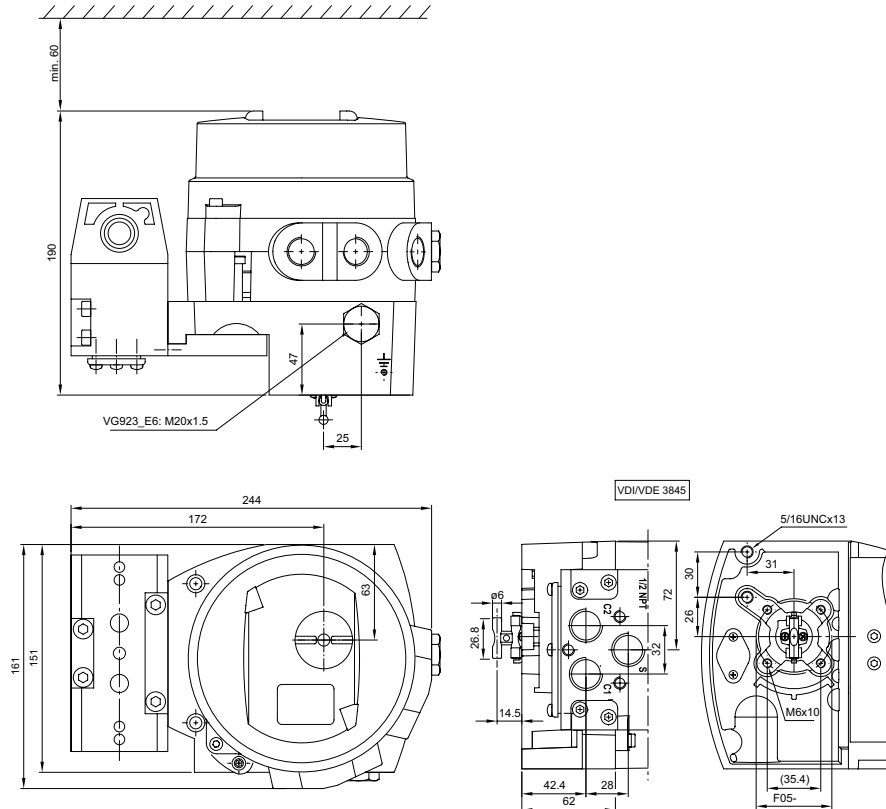

SG931\_

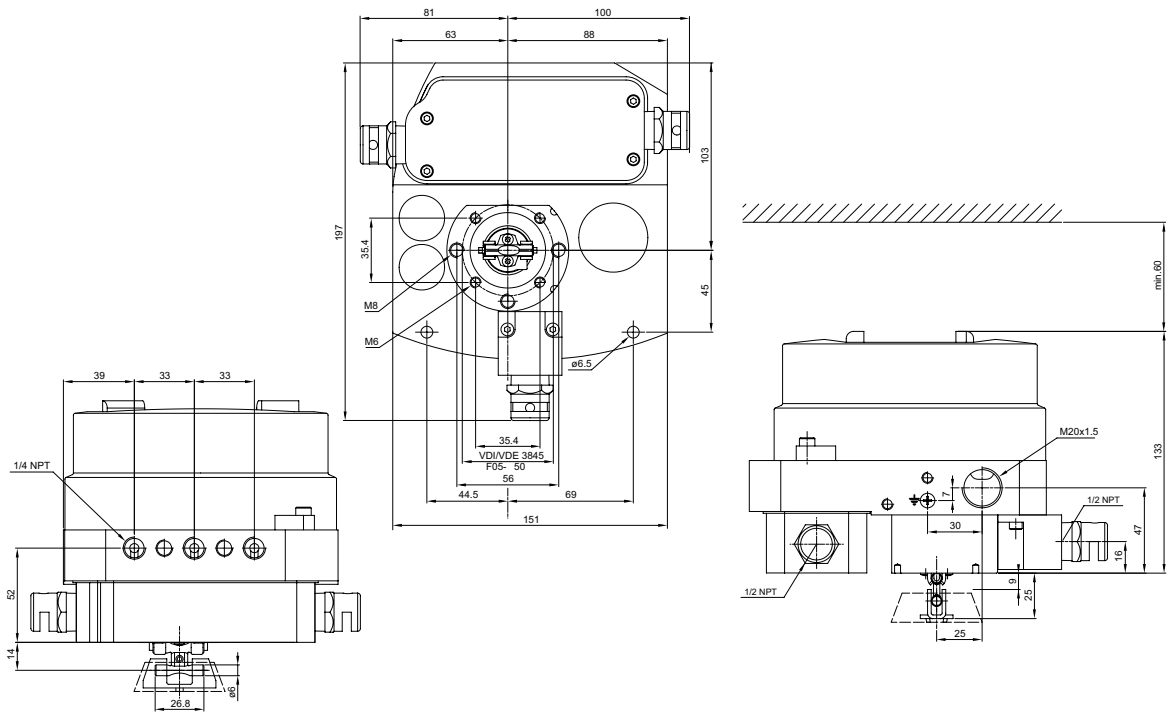

SG931\_J

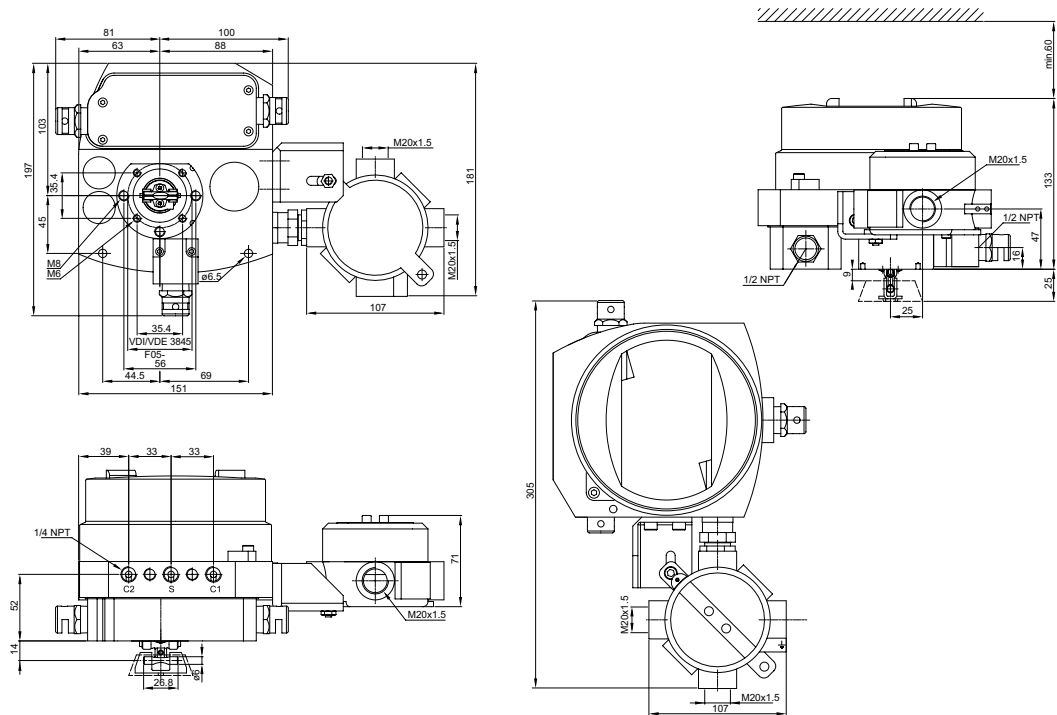

### SG931\_ with limit switches

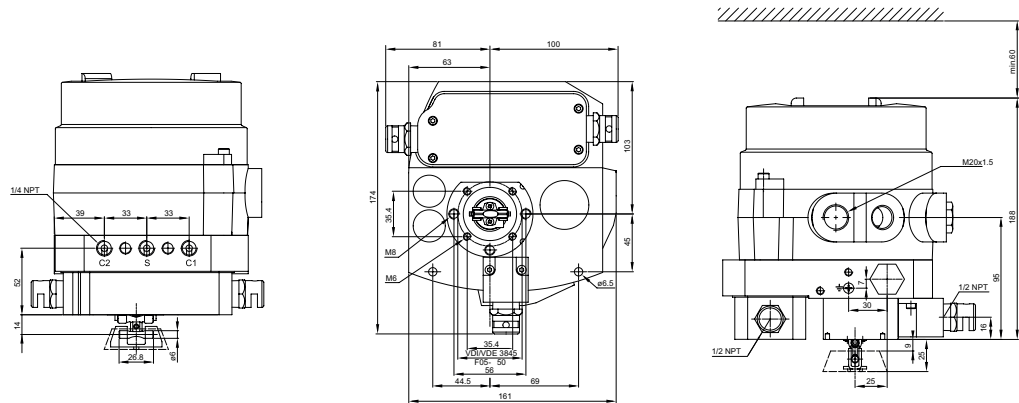

### SG931\_J with limit switches

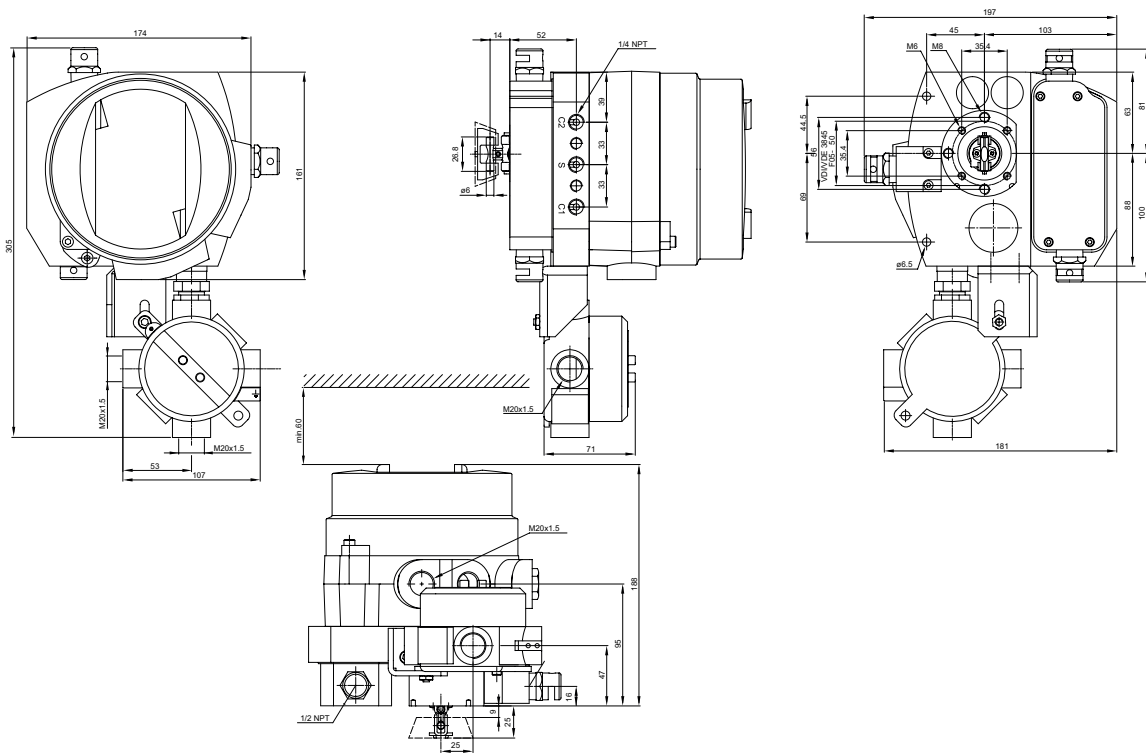



# 14. CONFIGURATION PARAMETERS

DTM			LUI *)	
Screen	Parameter	Values / Range	Parameter	Values / Range
	-	-	MODE	<b>AUTO, MAN</b>
	-	-	TUNE	<b>2 ... 20 (default 5)</b>
Settings	Frame Language	English, Suomi, Deutsch	LANG	<b>ENG, GER, FRE</b>
Operation Unit	HART Tag	free text (default POS1234)	-	-
	Description	free text (default SG9000)	-	-
	Device Date	free text (default 02.02.2005)	-	-
	Message	free text (default SG9000)	-	-
	HART Long Tag	free text (default SG9000)	-	-
Assembly Related	Actuator Type	Double Acting, Single Acting	ATYP	<b>2-A, 1-A</b>
	Valve Acting Type	Rotary, Linear	VTYP	<b>ROT, LIN</b>
	Maximum Valve Speed	Slow, Moderate, Fast	MAXS	<b>FST, SLO, STD</b>
	Dead Angle	0.0 ... 50.0 %	A0	<b>0.0 ... 99.0 %</b>
	Positioner Fail Action Direction	Close, Open	PFA	<b>CLO, OPE</b>
	Position Transmitter Direction	Normal Direction, Reverse, Not In Use	-	-
Signal Modification	Direction	Rising Setpoint to Open, Rising Setpoint to Close	DIR	<b>CLO, OPE</b>
	Setpoint Trigger Level	20.0 ... 80.0 % (default 50.0 %)	LEV	<b>20.0 ... 80.0 % (default 50.0 %)</b>
	SW Limit Switch - Closed Below	0.0 ... 100.0 % (default 0.0%)	-	-
	SW Limit Switch - Open Above	0.0 ... 100.0 % (default 100.0%)	-	-
Stroke Profile Open	Stroke Time	default 10 s	STOP	<b>0 ... 999</b>
	Stroke Profile Type	Linear, Slow Start, Slow Start and End, Equal Percentage, Quick Opening	SPOP	<b>1, 2, 3, 4, 5</b>
	Custom Profile	21 parameters, range 0.0 ... 100.0	-	-
Stroke Profile Close	Stroke Time	default 10 s	STCL	<b>0 ... 999</b>
	Stroke Profile Type	Linear, Slow Start, Slow Start and End, Equal Percentage, Quick Opening	SPCL	<b>1, 2, 3, 4, 5</b>
	Custom Profile	21 parameters, 0.0 ... 100.0	-	-
Monitoring Dynamic Variables	Sampling Rate	1 ... 60 s	-	-
Warnings Limit for Performance	Stroke Time Deviation - Open	0 ... n s (default 5 s)	-	-
	Stroke Time Deviation - Close		-	-
	Spool Valve Reaction Time - Open	0.0 ... 60.0 s (default 5 s)	-	-
	Spool Valve Reaction Time - Close		-	-
	Valve Reaction Time - Open	0.0 ... 60.0 s (default 10 s)	-	-
	Valve Reaction Time - Close		-	-
	Supply Pressure - Low Limit	2.0 ... 8.0 bar (default 2.5 bar)	-	-
	Supply Pressure - High Limit	2.0 ... 8.0 bar (default 7.5 bar)	-	-
	Temperature - Low Limit	-40.0 ... 85.0 °C (default -35 °C)	-	-
Temperature - High Limit	-40.0 ... 85.0 °C (default 80 °C)	-	-	
Warning Limits for Counters	Total Operation Time	0 ... n h (default 216000 h)	-	-
	Total Valve Full Strokes	0 ... n (default 2000000)	-	-
	Total Actuator Full Strokes		-	-
Alarm Limits	Stroke Time Deviation Open - High Limit	0 ... n s (default 5 s)	-	-
	Stroke Time Deviation Close - High Limit		-	-
	Valve Stuck Deviation - Position Deviation	0.0 ... 100.0 % (default 5.0 %)	-	-
	Valve Stuck Deviation - Latch Time	0 ... 999 s (default 30.0 s)	-	-
	Unallowed Valve Movement - Latch Time	0 ... n s (default 5 s)	-	-
	Supply Pressure - Low Limit	1.0 ... 10.0 bar (default 2.5 bar)	-	-
	Supply Pressure - High Limit	1.0 ... 10.0 bar (default 8 bar)	-	-
	Supply Pressure - Latch Time	0 ... n s (default 30 s)	-	-
	Temperature - Low Limit	-40.0 ... 85.0 °C (default -35 °C)	-	-
	Temperature - High Limit	-40.0 ... 85.0 °C (default 80 °C)	-	-
	Temperature - Latch Time	0 ... n s (default 120 s)	-	-
	Spool Valve Reaction Time - High Limit	0 ... n s (default 50 s)	-	-
	Supply Pressure Fail Action - Low Limit	0.0 ... 8.0 bar (default 1.0 bar)	-	-
	HART Configuration	1st Dynamic Variable Code	Setpoint, Valve Position, Cylinder Pressure (C1), Cylinder Pressure (C2), Actuator Pressure Difference, Supply Pressure, Device Temperature, Target Position	-
2nd Dynamic Variable Code		-		-
3rd Dynamic Variable Code		-		-
4th Dynamic Variable Code		-		-
Supply Pressure Unit		bar, psi	-	-
Pressure Difference Unit			-	-
Cylinder Pressure (C1) Unit			-	-
Cylinder Pressure (C2) Unit			-	-
Device Temperature Unit		°C, °F	-	-
Response Preambles		5 ... 20	-	-
Burst Mode Command		1, 2, 3, 9	-	-
1st Burst Variable Code		Setpoint, Valve Position, Cylinder Pressure (C1), Cylinder Pressure (C2), Actuator Pressure Difference, Supply Pressure, Device Temperature, Target Position	-	-
2nd Burst Variable Code			-	-
3rd Burst Variable Code			-	-
4th Burst Variable Code			-	-
Device HART Address		Multidrop	Disabled, Enabled	-
	Address	0, 1 ... 15	-	-

\*) Default values are set in boldface type

# 15. EU DECLARATION OF CONFORMITY



## EU DECLARATION OF CONFORMITY

Manufacturer:  
Neles Finland Oy  
01301 Vantaa  
Finland

Product: **Intelligent On/Off Valve Controller Neles SwitchGuard SG9000-series**

Approvals:

Type	Approval	EC Type examination Certificate
SG9_H/_/_	EMC 2004/108/EC	NEMKO 56164, NEMKO 80628, NEMKO 175885 EN61000-6-2(2005), EN 61000-6-4(2007) and FCC 47 CFR PART 15, SUBPART B, CLASS B (2002)
SG9_HX/_/_ (ATEX)	ATEX II 1 G Ex ia IIC T6...T4 Ga ATEX II 1 D Ex ta IIIC T90 °C Da	EESF 19 ATEX 045X EN IEC 60079-0:2018 EN 60079-11:2012 EN 60079-31:2014
	ATEX II 2 G Ex ib IIC T6...T4 Gb ATEX II 2 D Ex tb IIIC T90 °C Db	EESF 19 ATEX 046X EN IEC 60079-0:2018 EN 60079-11:2012 EN 60079-31:2014 EN 60079-15:2010
	ATEX II 3 G Ex nA IIC T6 ... T4 Gc ATEX II 3 D Ex tc IIIC T90 °C Dc ATEX II 3 G Ex ic IIC T6 ... T4 Gc ATEX II 3 D Ex tc IIIC T90 °C Dc	SIRA 11ATEX1006X EN 60079-0:2012, EN 60079-1:2007, EN 60079-31:2009
SG9_HE6/_/_ SG9_HE7/_/_	ATEX II 2 G Ex d IIC T6...T4 Gb ATEX II 2 D Ex tb IIIC T80 °C...T105 °C Db IP66	

As the products within our sole responsibility of design and manufacture may be used as parts or components in machinery and are not alone performing functions as described in Article 6(2) in the Machinery Directive (2006/42/EC), we declare that our product(s) to which this Declaration of Conformity relates must NOT be put into service until the relevant machinery into which it is to be incorporated has been declared in conformity with the provisions of the Machinery Directive.

The product above is manufactured in compliance with the applicable European directives and technical specifications/standards.

Protection from e.g. static electricity caused by the process or connected equipment must be considered by the user (EN 60079-14 §6).

The product do not possess any residual risk according to hazard analyses made under the applicable directives providing that the procedures stated by the Installation, Operation and Maintenance manual are followed and the product is used under conditions mentioned in the technical specifications.

### Applicable directives:

EMC 2004/108/EC Electrical  
ATEX 2014/34/EU Approved and Ex marked types  
SI 2016 No. 1107 for UK

### ATEX Notified Bodies for EC Type Examination Certificates:

**SIRA** (Notified body number 0518)  
Sira Certification Service  
CSA Group  
Unit 6, Hawarden Industrial Park  
Hawarden, Deeside, CHs 3US  
United Kingdom

### EESF (Notified body number 0537)

Eurofins Electric & Electronics Finland Oy  
Kivimiehentie 4  
FI-02150 Espoo  
Finland

Vantaa 11th November 2022

Janne Jussila, Quality Manager

Authorized person of the manufacturer within the European Community and UK

### Notified bodies for Quality Assurance:

ISO 9001:2015 DNV-GL 73538-2010-AQ-FIN-FINAS  
ATEX 2014/34/EU Annex IV Presafe 2460 Presafe 18 ATEX 91983Q Issue 1

### Det Norske Veritas AS (Presafe Notified body number 2460)

Veritasveien 1  
1322 Høvik, Oslo  
Norway

# 16. TYPE CODING

SWITCHGUARD SG9000H							
1.	2.	3.	4.	5.	6.	7.	8.
SG	9	2	15	H	E6	/	D33

1.	PRODUCT GROUP
SG	Neles SwitchGuard SG9000H, Intelligent On/Off Valve Controller.

2.	SERIES CODE
9	Series 9000 Intelligent on/off valve controller with universal shaft and attachment face according to standard VDI/VDE 3845. Relevant shaft adapter included in mounting kits. When SG9000 is separate delivery, shaft adapter kit needs to be ordered separately (see type coding for accessories).

3.	ENCLOSURE
	Standard temperature range -40° to +85 °C. M20 x 1.5 conduit entry.
2	Standard anodized aluminium enclosure, IP66 / NEMA 4X.
3	Stainless steel enclosure, IP66 / NEMA 4X, no glass window.

4.	SPOOL VALVE	CONNECTIONS
12	Restricted capacity. Stroke volume of actuator 0.3 - 6.7 dm <sup>3</sup> .	S, C1, C2 = 1/4 NPT
15	Standard capacity. Stroke volume of actuator > 0.6 dm <sup>3</sup> .	S, C1, C2 = 1/4 NPT
35	High capacity. Stroke volume of actuator > 3.5 dm <sup>3</sup> . Not applicable to 3. sign "3".	S, C1, C2 = 1/2 NPT
37	Extended capacity. For single acting actuators. Stroke volume of actuator > 6.5 dm <sup>3</sup> . Not applicable to 3. sign "3".	S = 1/2 NPT, C2 = 1 NPT

5.	COMMUNICATION / INPUT SIGNAL RANGE
H	4–20 mA, HART communication.

6.	APPROVALS FOR HAZARDOUS AREAS
N	No approvals for hazardous areas. Not applicable with 3. sign "3"
N7	No approvals for hazardous areas. Like 6. sign "N", but with Russian language ID plate.

X	<p><b>ATEX and IECEx certifications:</b>                      II 1 G Ex ia IIC T6...T4 Ga                      II 1 D Ex ia IIIC T90 °C...T120 °C Da                      II 1 D Ex ta IIIC T90 °C...T120 °C Da                      II 2 G Ex ib IIC T6...T4 Gb                      II 2 D Ex ib IIIC T90 °C...T120 °C Db                      II 2 D Ex tb IIIC T90 °C...T120 °C Db                      Temperature range: T4: -40 to +80 °C; T5: &lt; +65 °C; T6: &lt; +50 °C.                      II 3 G Ex nA IIC T6...T4 Gc                      II 3 D Ex ic IIIC T90 °C...T120 °C Dc                      II 3 D Ex tc IIIC T90 °C...T120 °C Dc                      II 3 G Ex ic IIC T6...T4 Gc                      II 3 D Ex ic IIIC T90 °C...T120 °C Dc                      II 3 D Ex tc IIIC T90 °C...T120 °C Dc                      Temperature range: T4: -40 to +85 °C; T5: &lt; +75 °C; T6: &lt; +60 °C.                      Available with or without limit switches. See 9. sign for available options.</p>
X7	<p><b>TR CU (Russian) certification:</b>                      0Ex ia IIC T6...T4 Ga X / Ex ia IIIC T95 °C...T125 °C Da X                      0Ex ia IIC T6...T4 Ga X / Ex ta IIIC T95 °C...T125 °C Da X                      1Ex ib IIC T6...T4 Gb X / Ex ib IIIC T95 °C...T125 °C Db X                      1Ex ib IIC T6...T4 Gb X / Ex tb IIIC T95 °C...T125 °C Db X                      2Ex nA IIC T6...T4 Gc X / Ex ic IIIC T95 °C...T125 °C Dc X                      2Ex nA IIC T6...T4 Gc X / Ex tc IIIC T95 °C...T125 °C Dc X                      2Ex ic IIC T6...T4 Gc X / Ex ic IIIC T95 °C...T125 °C Dc X                      2Ex ic IIC T6...T4 Gc X / Ex tc IIIC T95 °C...T125 °C Dc X                      Temperature range: Ta according to separate table (see certificate).                      Available with or without limit switches. See 9. sign for available options.</p>

6.	APPROVALS FOR HAZARDOUS AREAS
X8	<p><b>CCC (Chinese) certification:</b>                      Ex ia IIC T4~T6 Ga Ex iaD 20 T95/T110/T125                      Ex ib IIC T4~T6 Gb Ex ibD 21 T95/T110/T125                      Ex ic IIC T4~T6 Gc Ex icD 22 T95/T110/T125                      Ex nA IIC T4~T6 Gc                      Available with or without limit switches. See 9. sign for available options.</p>
U	<p><b>cCSAus certifications</b>                      Class I, Division 1, Groups A, B, C, and D; T4/T5/T6                      Ex ia IIC T4/T5/T6 Ga                      Class I, Zone 0 AEx ia IIC T4/T5/T6 Ga                      Temperature range: T4: -40 to +80 °C, T5: &lt; +65 °C, T6: &lt; +50 °C.                      Class I, Division 2, Groups A, B, C, and D; T4/T5/T6                      Ex nA IIC T4/T5/T6 Gc                      Class I, Zone 2 AEx nA IIC T4/T5/T6 Gc                      Temperature range: T4: -40 to +80 °C, T5: &lt; +65 °C, T6: &lt; +50 °C.                      Not applicable with 7. sign "J"                      Available with or without limit switches. See 9. sign for available options.</p>
Z	<p><b>INMETRO certifications:</b>                      Ex ia IIC T6...T4 Ga                      Ex ia IIC T6...T4 Gb                      Temperature range: T4: -40 to +80 °C; T5: &lt; +65 °C; T6: &lt; +50 °C.                      Ex nA IIC T6...T4 Gc Ex ic IIC T6...T4 Gc                      Temperature range: T4: -40 to +80 °C; T5: &lt; +65 °C; T6: &lt; +50 °C.                      Available with or without limit switches. See 9. sign for available options.</p>
E2	<p>Flameproof enclosure, 1/2 NPT conduit entry.  <b>cCSAus certifications:</b>                      Class I, Div 1, Groups B, C, D; Class II, Div 1, Groups E,F,G; Class III;                      T6...T4, Enclosure type 4X                      Ex d IIC T6...T4                      AEx d IIC T6...T4                      Ex tb IIIC T100 °C IP66                      AEx tb IIIC T100 °C IP66                      Temperature range: T6: -40 °C to +60 °C; T5: &lt; +75 °C; T4: &lt; +85 °C.                      Available with or without limit switches. See 9. sign for available options.</p>
E5	<p><b>INMETRO certifications:</b>                      Ex db IIC T5 Gb (-40°C or -25°C Ta +85°C)                      Ex db IIC T6 Gb (-40°C or -25°C Ta +70°C)                      Available with or without limit switches. See 9. sign for available options.</p>
E6	<p><b>ATEX and IECEx certifications:</b>                      II 2 GD                      Ex d IIC T6...T4 Gb                      Ex tb IIIC T80 °C...T105 °C Db IP66                      Temperature range: Ta according to separate table (see certificate).                      Available with or without limit switches. See 9. sign for available options.</p>
E7	<p><b>TR CU (Russian) certification:</b>                      1Ex d IIC T6...T4 Gb X / Ex tb IIIC T80 °C...T105 °C Db X                      Temperature range: Ta according to separate table (see certificate).                      Available with or without limit switches. See 9. sign for available options.</p>
E8	<p><b>CCC (Chinese) certification:</b>                      Ex d IIC T4~T6 Gb Ex tD A21 IP66 T80 °C/T95 °C/T105 °C                      Available with or without limit switches. See 9. sign for available options.</p>

7.	OPTIONS OF VALVE CONTROLLER
	Several options can be selected, but the order shown below needs to be maintained.
T	Internal 2-wire (passive) position transmitter. Analog position feedback signal, output 4–20 mA, supply voltage 12–30 V DC, external load resistance 0–780 Ω.
J	External junction box, 2 pcs M20x1.5 conduit entry. NOT applicable to 6. sign "E2" Junction box for all 4–20 mA wirings, including position transmitter, if applicable. Junction box is attached to the standard enclosure. Not available with 6. sign "U".
Y	Special construction, to be specified.

8.	LIMIT SWITCH TYPE
	<b>Inductive proximity switches, 2 pcs.</b> IP 66 / NEMA 4X enclosure. M20x1.5 conduit entry (2 pcs)
D33	Obsolete, select R01 option instead
D44	Obsolete Select replacement from other NAMUR switch options
I02	P+F; NJ2-12GK-SN, 2-wire type, DC; > 3 mA; < 1 mA, NAMUR NC. Intrinsically safe according to ATEX II 1 G Ex ia IIC T6. Temperature range -40° to +85 °C / -40° to +185 °F.
I09	P+F; NCB2-12GM35-N0, 2-wire type, DC; > 3 mA; < 1 mA, NAMUR NC. Intrinsically safe according to ATEX II 2 G Ex ia IIC T6. Temperature range -25° to +85 °C / -13° to +185 °F.
I32	Omron; E2E-X2Y1; 2-wire type; AC; <100mA; 24-240VAC. Temperature range: -40° to +85 °C / -40° to +185 °F Temperature range -40 to +85 °C / -40 to +185 °F. Not applicable to 6. sign "X", "Z" or "U"
I45	P+F; NJ3-18GK-S1N, 3-wire type, DC; > 3 mA; < 1 mA, NAMUR NO. Intrinsically safe according to ATEX II 1 G Ex ia IIC T6. Temperature range -25° to +85 °C / -13° to +185 °F.
I56	ifm; IFC2002-ARKG/UP, 2-wire type, DC; 150 mA, 10 - 36 V DC, leakage current < 0.6 mA. Temperature range -25° to +80 °C / -13° to +176 °F. Not applicable to 6. sign "X", "Z", or "U"
I57	2 pcs, P+F; NJ2-V3-N, 2-wire type, DC; > 3 mA; < 1 mA, NAMUR NC. Intrinsically safe according to ATEX II 1 G Ex ia IIC T6 Ga. Temperature range -25 to +85 °C / -13 to +185 °F.
I58	4 pcs, P+F; NJ2-V3-N, 2-wire type, DC; > 3 mA; < 1 mA, NAMUR NC. Intrinsically safe according to ATEX II 1 G Ex ia IIC T6 Ga. Temperature range -25 to +85 °C / -13 to +185 °F.
I60	P+F; NCB2-12GM40-E2-3G-3D, 3-wire type, PNP NO, 0...200 mA, 10...30 V DC Intrinsically safe according to ATEX II 2 G Ex ia IIC T6. Temperature range -25 to +70 °C / -13 to +158 °F. Applicable to 6. sign "X" (nA approval only, suitable for Zone 2) and all other approval options
	<b>Reed Type Proximity Switches, 2 pcs.</b> IP 66 / NEMA 4X enclosure. M20x1.5 conduit entry (2 pcs) Temperature range -40° to +80 °C / -40° to +176 °F
R01	Valmet Maxx-Guard G, SPDT, 300 mA, 24 V DC; 200 mA, 125 V AC Not applicable to 8. sign "X", "Z" or "U"
R02	Valmet Maxx-Guard M, Reed, SPDT, passive, intrinsically safe, 300 mA, 24 VDC Temperature range -40...+80°C / -40...+176 °F.
R04	Valmet Maxx-Guard H, Reed, SPDT, V <sub>max</sub> 240 v, I <sub>max</sub> 3A, V <sub>max</sub> 100W. Temperature range -40...+80°C / -40...+176 °F. Not applicable to 8. sign "X", "Z" or "U"
	<b>Mechanical micro switches</b> IP 66 / NEMA 4X enclosure. Temperature range -40 to +85 °C / -40 to +185 °F
K25	2 pcs. Omron D2VW-5L2A-1MS; 3 A – 250 V AC, 0.4 A – 125 V DC, 5 A – 30 V DC. Not applicable to 6. sign "X", "Z", or "U".
K26	2 pcs. Omron D2VW-01L2A-1MS; gold plated contacts, 100 mA – 30 V DC / 125 V AC. Not applicable to 6. sign "X", "Z", or "U".
K45	4 pcs. Omron D2VW-5L2A-1MS; 3 A – 250 V AC, 0.4 A – 125 V DC, 5 A – 30 V DC. Not applicable to 6. sign "X", "Z", or "U".
K46	4 pcs. Omron D2VW-01L2A-1MS; gold plated contacts, 100 mA – 30 V DC / 125 V AC. Not applicable to 6. sign "X", "Z", or "U".

OPTIONAL DEVICES FOR SG9000	
U24	<b>U/I converter</b> Seneca; K109UI (H062181) Input voltage 0–30 V DC Power/Supply: 19.2–30 V DC Power Consumption: 500 mW

## ADDITIONAL ACCESSORIES

-- □	FILTER REGULATORS
	<b>SG9215</b> Filter regulator for supply air. Filter size 5 µm. Pressure gauge, scale bar/psi/kPa, basic material brass, nickel plated, housing stainless steel, glycerine filled. Temperature range -40 °C... +82 °C / -40 °F... +180 °F.
K	K option includes a thread nipple 1/4"NPT to 1/4"NPT which is suitable with SG9200 & SG9300 option A3 (1/4NPT AIR CONNECTION)  A large capacity filter regulator (not K) must be used for actuator bigger than BC 40 and BJ 32. Installation with mounting bracket. Use large capacity filter regulator also with SG923_. A large capacity filter regulator (not K) must be used for actuator bigger than BC 40 and BJ 32. Installation with mounting bracket.

-- □	CONDUIT ENTRY NIPPLES
CE07	1/2 NPT conduit entry nipples M20x1,5 / 1/2 NPT Code: H037029
CE09	1/2 NPT conduit entry nipples <b>Brass M20x1,5 / 1/2 NPT, E xd approved</b> Code: K0148
CE19	1/2 NPT conduit entry nipples <b>stainless steel M20x1.5 / 1/2 NPT, E xd approved</b> Code: H7599

-- □	CABLE GLANDS
CG5	M20 x 1,5 for Valmet limit switches, SG92_N_ code H6870 grey/ plastic, IP66 )
CG6	M20 x 1,5 blue/plastic, IP66, Ex e

-- □	PRESSURE GAUGES AND CONNECTION BLOCKS
	Pressure gauge A3: scale bar/psi/kPa (bar/psi/ kg/cm <sup>2</sup> ), <b>basic material brass, nickel plated, housing stainless steel</b> AISI 304, glycerine filled. Temperature range -40...+85 °C / -40...+185 °F. Pneumatic connection block, material AISiMg, anodized grey.
A3	Pressure gauges with connections 1/4 NPT (S, C1, C2) for VG921_ . AISI 304
A7	Pressure gauges with connections 1/4 NPT for VG93_ . AISI 316
A8	Pressure gauges with connections 1/2" NPT (S, C1, C2) for VG9235_ . AISI 304
A9	Pressure gauges with connections 1/2" NPT (S) and 1" NPT (C2) for VG9237_ . AISI 304
A10	Pressure gauges with connections 1/4 NPT for SG93_ . AISI 316, pressure gauges for severe off-shore use, safety glass window.







**Valmet Flow Control Oy**

Vanha Porvoontie 229, 01380 Vantaa, Finland.

Tel. +358 10 417 5000.

[www.valmet.com/flowcontrol](http://www.valmet.com/flowcontrol)

Subject to change without prior notice.

Neles, Neles Easyflow, Jamesbury, Stonel, Valvcon and Flowrox, and certain other trademarks, are either registered trademarks or trademarks of Valmet Oyj or its subsidiaries in the United States and/or in other countries.

